

# FS-04



## Technical Specifications

- The main bearing housings of all the tools included in this Set are  $\varnothing$  min.139 mm. in diameter and min. 2.5-3 mm. it is made of wall-thick metal pipe.
- The carrier and moving parts connected to the main body are manufactured from a metal pipe with a diameter of  $\varnothing$  60-89 mm and a wall thickness of 2.5-3 mm.
- Non-movable accessory parts connected to the main body are manufactured from metal pipes with a diameter of  $\varnothing$  33 and a wall thickness of 2.5-3 mm.
- Except for the moving parts to be welded together with the main body and all the parts to be permanently connected to the body, all fixed parts are produced in such a way as to form a single body.
- Rolling bearings of the type that will not be affected by weather conditions are used in the moving parts, they are equipped with double bearings in which the bearings are hidden and joint mechanisms.
- The internal mechanisms are manufactured in a closed system that does not allow interference during normal use.
- All joint designs are designed to prevent weld ruptures and one-sided loading
- In order for the pipes welded to the connection hubs to join each other completely, the crushing process is not performed at the pipe mouths.
- While the body and pipes are being connected, a doetail is opened at the radius suitable for the pipes and the pipes are welded on all sides.
- The arms, seats, backrests, mounting covers, armrests and footrests of all products are produced from polyethylene material in self-colored or special twisted industrial pipes by rotation, inflation and injection plastic method resistant to ultraviolet rays.
- On the other hand, colored pullers are installed that are specially made of rubber / plastic, which are given such tightness that they will not come off by themselves and can not be removed by the user.
- In addition, the carrier main pipe flange plates of all products are closed with polyethylene anchor covers.
- All sheet materials used in the products are laser cut.
- Polyethylene pipe covers covering the upper part of the main carrier pipes are produced by injection method with hemispherical and reinforcement added to increase the strength in the inner upper part.

## **Electrostatic Powder Coating**

- After the material is coated with polyester-based powder coating, which prevents the metal from being heated by the sun in the electrostatic system, the painting process is completed by baking in the oven at a temperature of at least 180-200 degrees for 15-20 minutes.

## **Leg Streching Equipment**

- The load-bearing pipes are at least Ø 139 mm and 2.5-3 mm wall thickness it is manufactured from min. 1270 mm long pipe.
- Anchor plugs with a diameter of Ø139 mm are used to close open-ended pipes in fitness products.
- Anchor caps are produced from polyethylene plastic material with LLDPE (Linear Low Density Polyethylene) injection method.
- It is resistant to UV rays and is designed not to harm the user.
- A circularly bent handle made of Ø 33 mm 2.5-3 mm thick pipe is mounted on the main body so that the user can get support with his hands while working.
- The moving parts connected to the main body are manufactured with a minimum Ø 60 mm and a wall thickness of 2.5-3 mm.
- In order to connect the movable joints on the main body; The pipe with Ø 60 mm 2,5-3 mm wall thickness is fixed by welding as a single piece by drilling holes on the 2 surfaces of the upper part of the Ø 139 mm main body in order to increase the strength.
- The third hand-holding zone is made of ergonomically designed polyethylene material or 34x3 mm special twisted pipe so that two people can use it from a single center
- 2 pcs 6006 2RS Bearings are used in the three Movable joint hubs.
- Moving parts are manufactured by bending the pipe with Ø 60 mm and 3 mm thickness in accordance with it.
- In order to eliminate the risk of the main acting components hitting the body, two Ø 60 mm diameter and 40 mm high rubber stopping wedges are placed on the body pipe.
- In the foot pressing section, there are 4 foot pressing pedals made of fiber-blended polyethylene material by injection printing method.

- In order not to slip the foot, it will be patterned on top, the footrest is fixed to 5 mm thick sheet metal.
- The main body flashes are manufactured by laser cutting from ST37 sheet with a thickness of 8 mm and a size of 280x280 mm and are reinforced with flag sheets with a thickness of 5 mm in order to increase their strength.

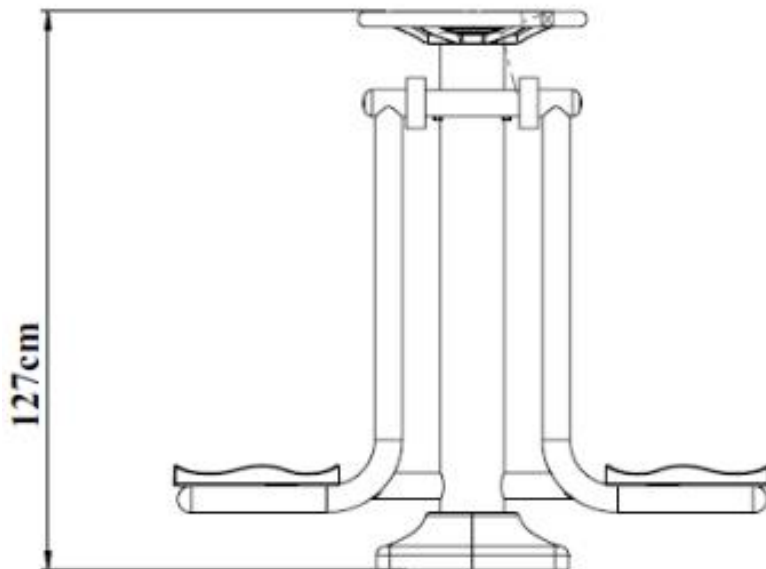
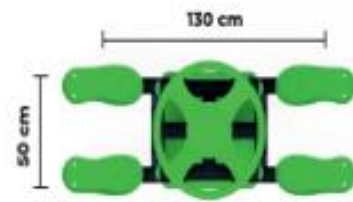
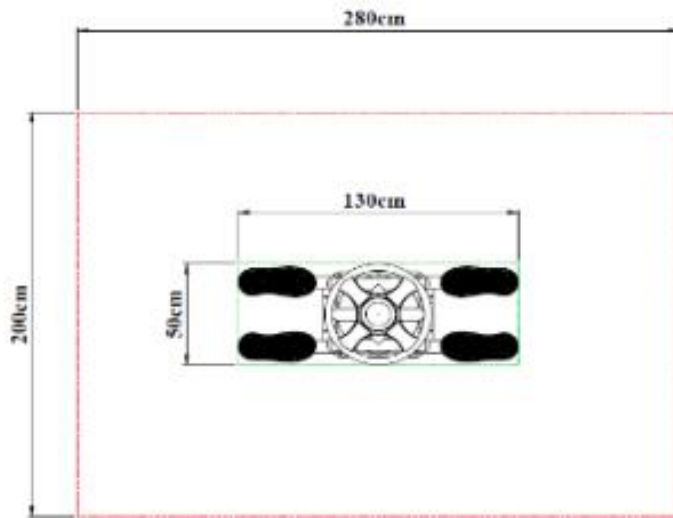

<b>Dimensions</b>	Width	50 cm
	Length	130 cm
	Height	127 cm

## Push-off Legs Equipment

- The internal carrier pipes are at least  $\text{Ø } 139 \text{ mm}$  it is manufactured from a pipe with a length of min. 1840 mm and a wall thickness of 2.5-3 mm.
- Anchor plugs with a diameter of  $\text{Ø } 139 \text{ mm}$  are used to close open-ended pipes in fitness products.
- Anchor caps are produced from polyethylene plastic material with LLDPE (Linear Low Density Polyethylene) injection method.
- It is resistant to UV rays and is designed not to harm the user.
- It is produced as double-walled and assembled with screwing system.
- The moving parts connected to the main body are produced as a single piece with a minimum  $\text{Ø } 60 \text{ mm}$  and 2.5-3 mm wall thickness and specially bent.
- Two 6205 2RS Bearings are used in the movable U-joint hubs.
- The leg support component, which is welded to the body, is manufactured from  $\text{Ø } 33 \text{ mm}$  pipe, twisted, in an aesthetic and robust structure.
- Seats and backrests are made of self-colored polyethylene material.
- The foot part is manufactured from specially bent pipe with a diameter of  $\text{Ø } 33 \text{ mm}$  and a thickness of 2.5-3 mm.
- The main body flashers are laser-cut from 8 mm thick 280x280 mm ST37 sheet, and the flange strength is increased by welding 4 flag sheets.

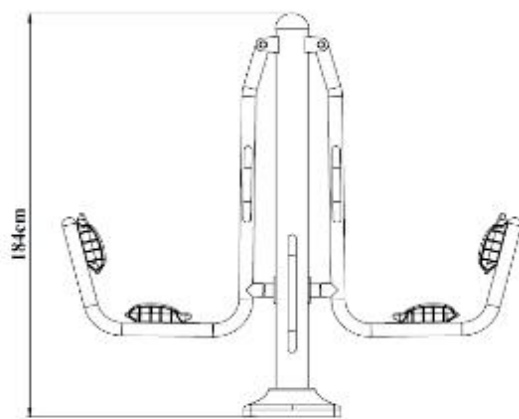
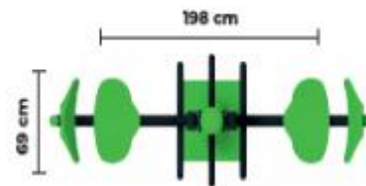
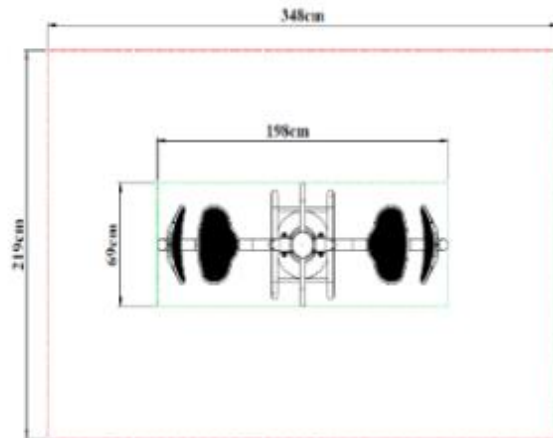

<b>Dimensions</b>	Width	68 cm
	Length	198 cm
	Height	184 cm

## Double Walker

- The load-bearing pipes are at least  $\text{Ø } 139$  mm and 2.5-3 mm wall thickness and it is manufactured from a min 1530 mm long pipe.
- The upper part of the carrier main body is covered with a pipe cover made of polyethylene material by injection method.
- Anchor plugs with a diameter of  $\text{Ø } 139$  mm are used to close open-ended pipes in fitness products.
- Anchor caps are produced from polyethylene plastic material with LLDPE (Linear Low Density Polyethylene) injection method.
- It is resistant to UV rays and is designed not to harm the user.
- It is produced as double-walled and assembled with screwing system.
- The moving parts connected to the main body are at least  $\text{Ø } 60$  mm and 2.5-3 mm wall thickness.
- The footrest part is manufactured from a 40x80 mm profile with a length of 1500 mm, and a colored footrest made of plastic material by injection method is mounted on it as a footrest.
- The joint connection pipes in the movable section of the walking system are made of  $\text{Ø } 60$  mm 2.5-3 mm thick pipes.
- $\text{Ø } 60$  mm joint connection pipes are welded all around the joint connections from the bottom and top.
- Bearings 6205 2 RS and 6006 2RS are used in the Joint Joints.
- Special twisted pipes with a thickness of  $\text{Ø } 33$  mm 2.5-3 mm are welded to the upper joint connections.
- Colored rubber pullers are attached to the hand-holding parts.
- The main body flashes are manufactured by laser cutting from ST37 sheet with a thickness of 8 mm and a size of 280x280 mm and 4 pieces of flag sheet are welded in order to increase the flange strength.

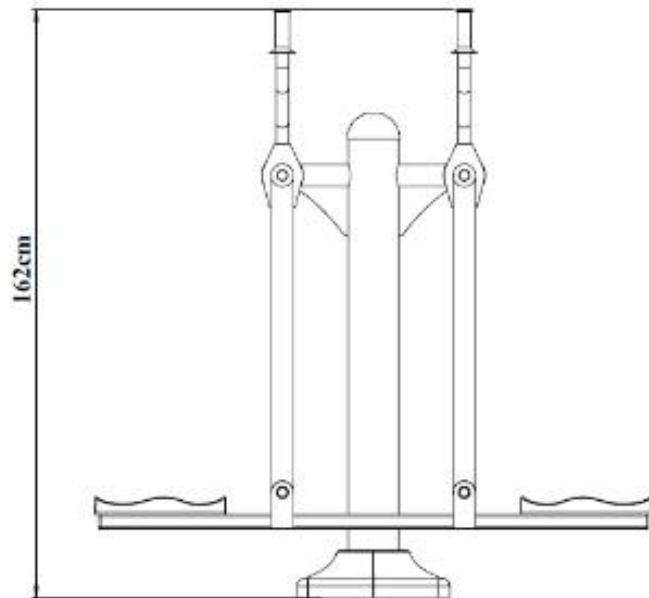
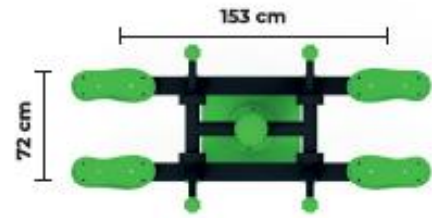
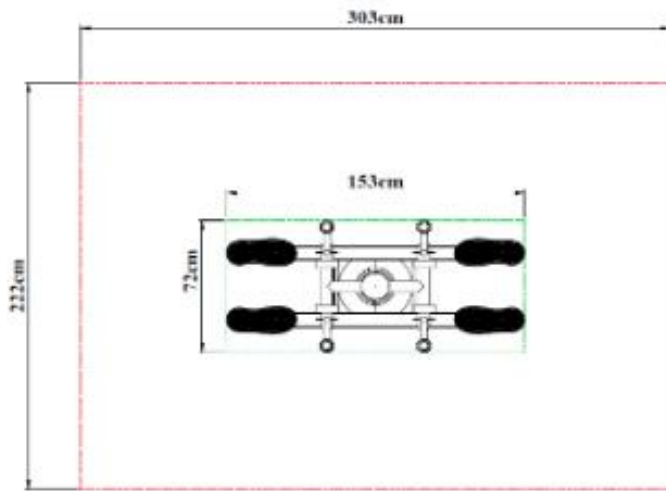

<b>Dimensions</b>	Width	72 cm
	Length	153 cm
	Height	162 cm



## Double Waist Streching Equipment

- Carrier pipes are manufactured from pipes with Ø 139 mm, wall thickness of 2.5-3 mm and a length of at least min 1290 mm.
- Anchor plugs with a diameter of Ø139 mm are used to close open-ended pipes in fitness products.
- Anchor caps are produced from polyethylene plastic material with LLDPE (Linear Low Density Polyethylene) injection method.
- It is resistant to UV rays and is designed not to harm the user.
- It is produced as double-walled and assembled with screwing system.
- The moving parts connected to the main body are at least Ø 60 mm and 2.5-3 mm wall thickness.
- 2 pieces of 6006 2RS Ball Bearings are used in the three Movable joint hubs.
- Moving parts are manufactured by bending the pipe with Ø 60 mm and 3 mm thickness in accordance with it.
- A circularly bent handle made of Ø 33 mm 2.5-3 mm thick pipe is mounted on the main body so that the user can get support with his hands while working.
- In the foot pressing section, there are 4 foot pressing pedals made of fiber-blended polyethylene material by injection printing method.
- In order to prevent the foot from slipping, the patterned edges are raised and the footrest is fixed to a 5 mm thick sheet metal.
- The pivoting shaft, which is connected to the main body, is fixed as one piece by pulling the welding all around, and 4 pcs 6006 2rs bearings are used for the moving parts.
- The main body flashes are manufactured by laser cutting from ST37 sheet with a thickness of 8 mm and a size of 280x280 mm and are reinforced with flag sheets with a thickness of 5 mm in order to increase their strength.

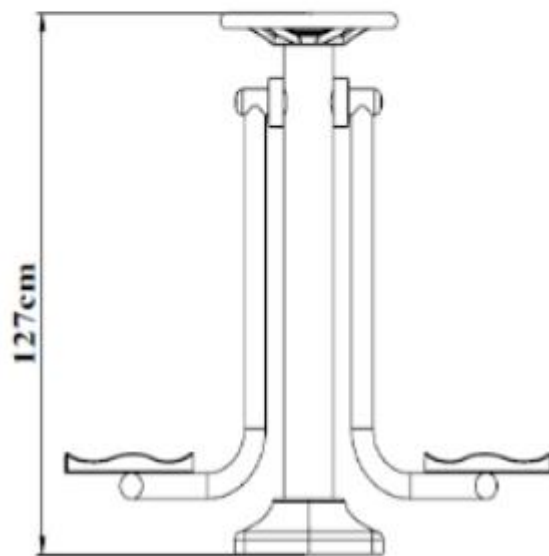
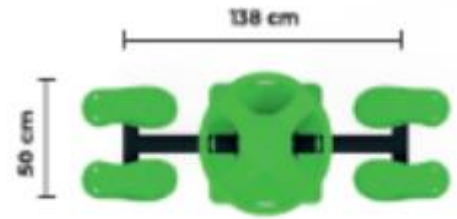
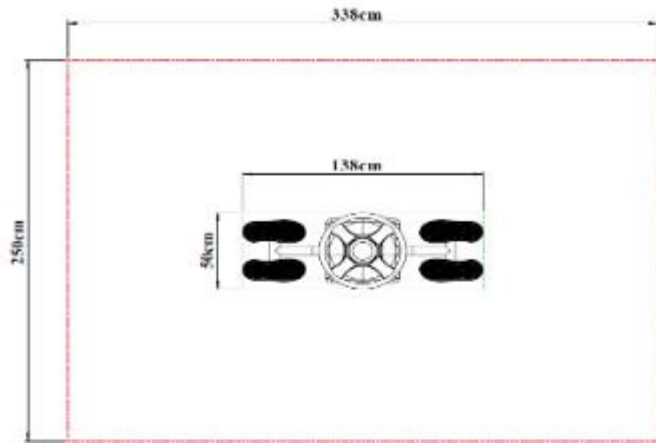

<b>Dimensions</b>	Width	44 cm
	Length	129 cm
	Height	133 cm

## **Wrist and Arm Exercise Equipment**

- Carrier pipes are manufactured from pipes with Ø 139 mm, wall thickness of 2.5-3 mm and a length of at least min 1160 mm.
- Anchor plugs with a diameter of Ø139 mm are used to close open-ended pipes in fitness products.
- Anchor caps are produced from polyethylene plastic material with LLDPE (Linear Low Density Polyethylene) injection method.
- It is resistant to UV rays and is designed not to harm the user.
- It is produced as double-walled and assembled with screwing system.
- The upper part of the main carrier body is closed with a pipe cover made of polyethylene material by injection method.
- The moving parts connected to the main body are at least Ø 60 mm and 2.5-3 mm wall thickness.
- In addition, 2 pieces of 6205 2 RS type bearings are used in each movable hub.
- The connection pipes are twisted from the Ø 60 mm pipe in such a way as to give an aesthetic appearance it is manufactured.
- The connection pipes are manufactured with 5 mm thick sheets in such a way that they can be easily disassembled and installed.
- Lever turning discs are manufactured from polyethylene material in a robust and aesthetic structure.
- There are spinning tops that will make it easier to hold the ball on the playing surface and circular reliefs on the entire surface.
- The main body flashes are manufactured by laser cutting from ST37 sheet metal with a thickness of 8 mm and a size of 280x280 mm.

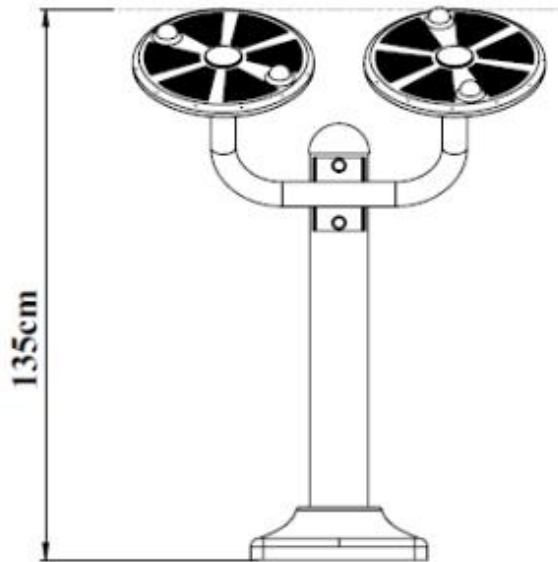
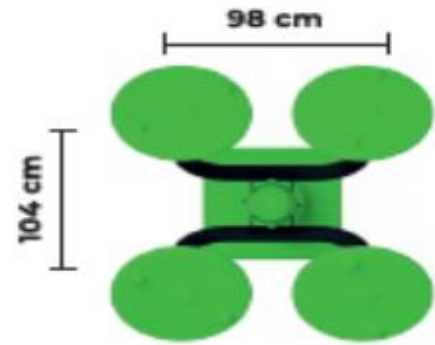
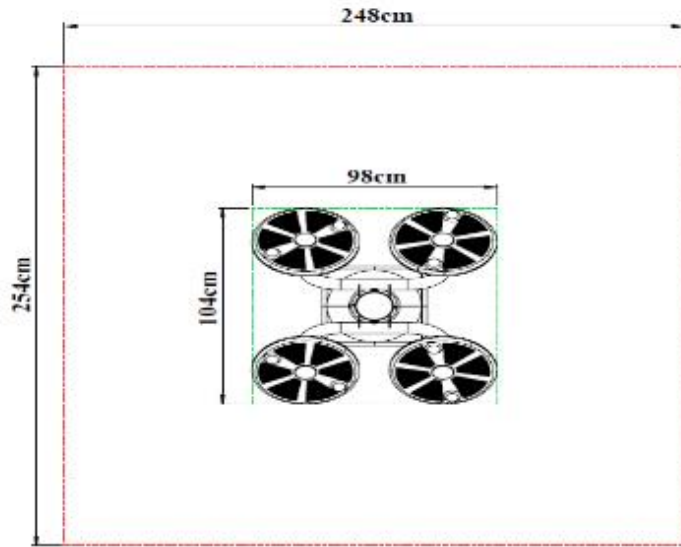

<b>Dimensions</b>	Width	104 cm
	Length	116 cm
	Height	135 cm

## Sit Ups Equipment

- The carrier pipes are manufactured from pipes with a diameter of at least Ø 139 mm, a length of min 950 mm and a wall thickness of 2.5-3 mm.
- Anchor plugs with a diameter of Ø139 mm are used to close open-ended pipes in fitness products.
- Anchor caps are produced from polyethylene plastic material with LLDPE (Linear Low Density Polyethylene) injection method.
- It is resistant to UV rays and is designed not to harm the user.
- It is produced as double-walled and assembled with screwing system.
- The upper part of the main carrier body is closed with a pipe cover made of polyethylene material by injection method.
- The appropriate bending is given to the Ø 33 mm pipe and the holding place is formed.
- The top of the inner carrier pipe is closed with a plastic plug.
- Carrier pipes are produced from Ø 90 mm 2,5-3 mm thick pipe
- Reclining frame is manufactured from Ø 60 mm 2,5-3 mm thick pipe specially bent, and the parts connected to the main body are manufactured from Ø 90 mm and 3 mm thick material and the 2 mm thick swivel sheet is manufactured with specially bent edges.
- Sheet metal clamps with a thickness of 5 mm are used to fix the recliners to the main body.
- The product is designed with functionality that allows 2 people to do sit-ups and push-ups at the same time.
- The main body flashes are manufactured by laser cutting from ST37 sheet metal with a thickness of 8 mm and a size of 280x280 mm.

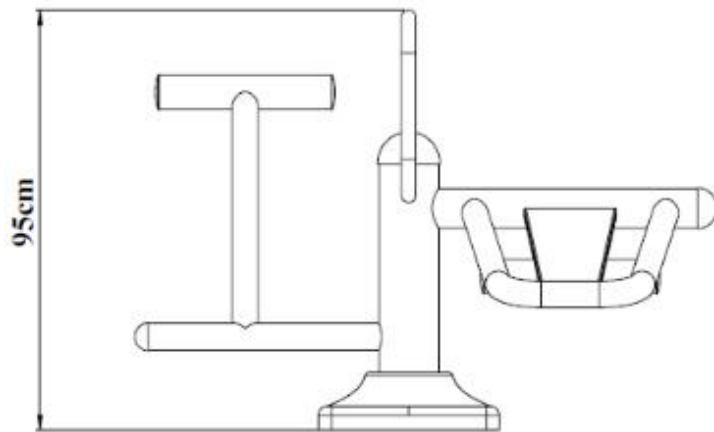
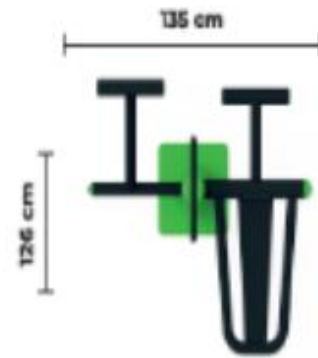
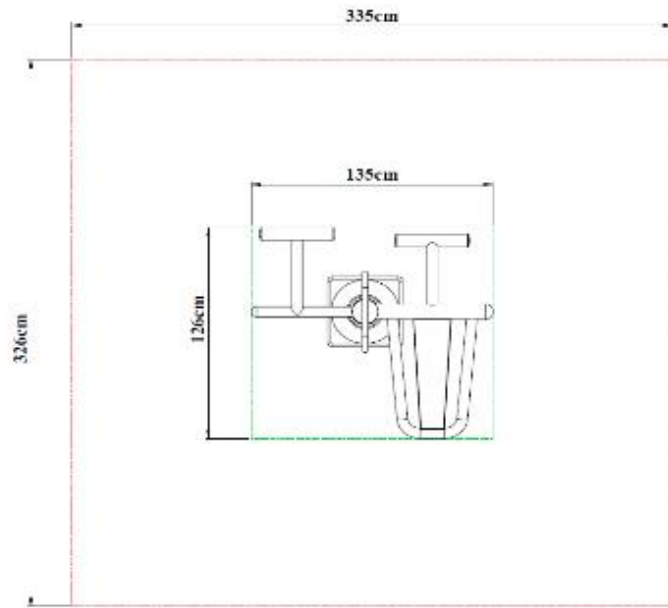

<b>Dimensions</b>	Width	135 cm
	Length	126 cm
	Height	95 cm

## Waist Stretching Equipment By Sitting and Standing

- The carrier pipes are manufactured from pipes with a diameter of at least  $\text{Ø} 139$  mm, a length of min 1270 mm and a wall thickness of 2.5-3 mm.
- Anchor plugs with a diameter of  $\text{Ø}139$  mm are used to close open-ended pipes in fitness products.
- Anchor caps are produced from polyethylene plastic material with LLDPE (Linear Low Density Polyethylene) injection method.
- It is resistant to UV rays and is designed not to harm the user.
- It is produced as double-walled and assembled with screwing system.
- Depending on the request, the product is produced in the form of a single main body or three separate parts.
- The parts connected to the main body are at least  $\text{Ø} 90$  mm and 2.5-3 mm wall thickness.
- The assembly moving parts are manufactured in  $\text{Ø} 60$  mm and 2.5-3 mm thickness.
- A Colored handle made of polyethylene material or a circularly bent handle made of  $\text{Ø} 33$  mm 2.5-3 mm thick pipe is mounted on the main body so that the user can receive support with his hands while working.
- There is an internal stop system and a foot stepping platform made of  $\text{Ø} 60$  mm 2.5-3 mm thick pipe in the movable section of the waist operating section with a seat.
- Polyethylene seat produced by injection technique is used in the seat part.
- The revolving platforms in two standing waist training stations are made of  $\text{Ø} 300$  mm embossed sheet with a thickness of 2.5-3 mm to prevent the user's feet from slipping.
- The circular edge of the rotary platform is reinforced with metal material with a thickness of 2.5-3 mm and a width of 16 mm.
- In the product, six pcs of 6205 2RS bearings are used.
- The main body flashes are manufactured by laser cutting from ST37 sheet metal with a thickness of 8 mm and a size of 280x280 mm.
- In order to increase the strength of the flange, it is reinforced with flag sheets with a thickness of 5 mm.

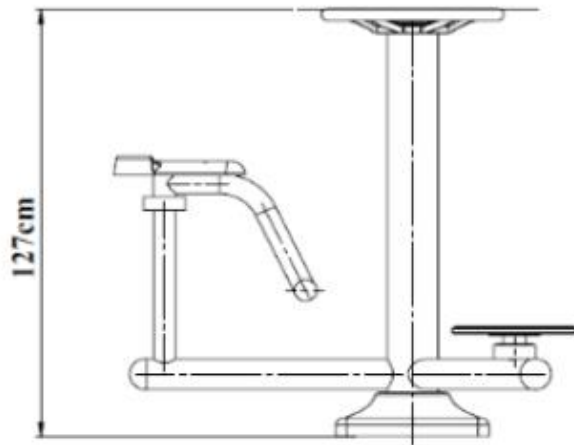
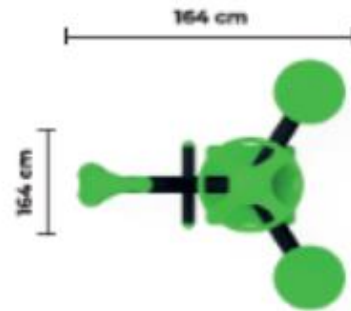
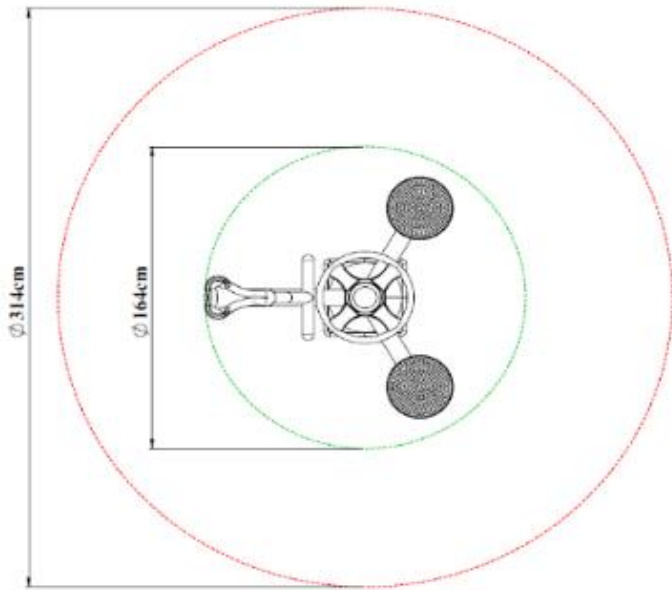

<b>Dimensions</b>	Width	164 cm
	Length	164 cm
	Height	127 cm



## Step-Bicycle Equipment

- Carrier pipes are manufactured from pipes with  $\text{Ø}$  139 mm, wall thickness of 2.5-3 mm and a length of at least min 1270 mm.
- Anchor plugs with a diameter of  $\text{Ø}$ 139 mm are used to close open-ended pipes in fitness products.
- Anchor caps are produced from polyethylene plastic material with LLDPE (Linear Low Density Polyethylene) injection method.
- It is resistant to UV rays and is designed not to harm the user.
- It is produced as double-walled and assembled with screwing system.
- The parts connected to the main body are manufactured with a wall thickness of at least  $\text{Ø}$  90 mm and 2.5-3 mm.
- A colored handle made of polyethylene material or a circularly bent handle made of a  $\text{Ø}$  33 mm 2.5-3 mm thick pipe is mounted on the main body so that the user can receive support with his hands while working.
- In the product, the bicycle tool seat is produced by injection method from polyethylene material.
- The step play section is assembled and fixed to the play core from 2 pieces of sheet metal with a thickness of 8 mm by welding.
- 2 pieces of  $\text{Ø}$  60 mm 40 mm high rubber stopping wedges are used in the movable part.
- Four pieces 6205 2RS two pieces 6006 2RS two pieces 30x55 mm tapered roller bearings are used in the product.
- Stepper tool footrests are made of self-colored plastic material.
- 5 mm thick support sheet is boiled under the footrests.
- The main body flashes are laser cut from ST37 sheet with a thickness of 8 mm and a size of 280x280 mm and are reinforced with flag sheets with a thickness of 5 mm in order to increase their strength.
- The movable assembly of the bicycle pedal is fixed with a tapered clamping bearing.
- Bicycle pedals are produced with two pieces of injection polyethylene material and the movable part with bearings.

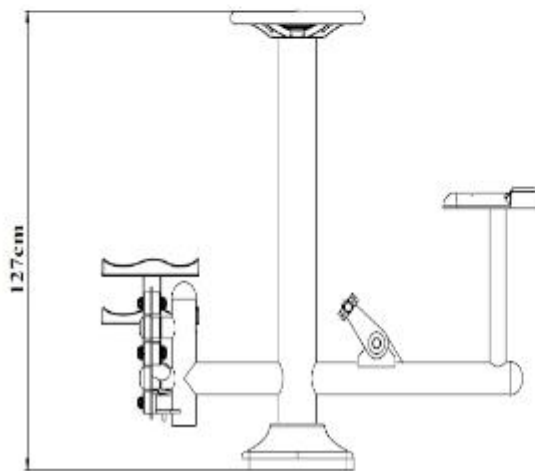
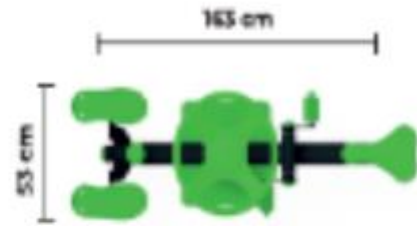
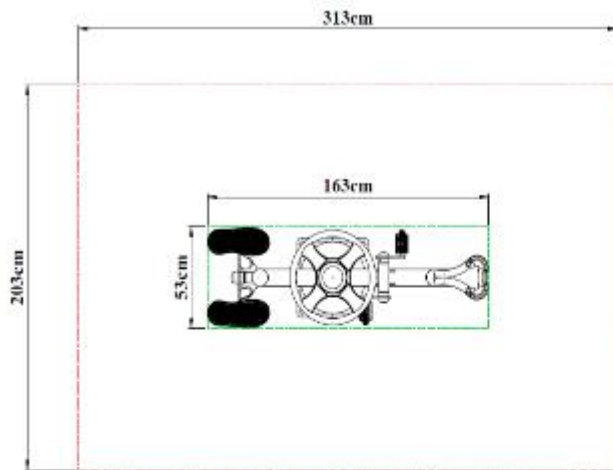

<b>Dimensions</b>	Width	53 cm
	Length	163 cm
	Height	127 cm

## Single Walker

- Carrier pipes are manufactured from pipes with  $\text{Ø}$  139 mm, wall thickness of 2.5-3 mm and a length of at least min 1350 mm.
- Anchor plugs with a diameter of  $\text{Ø}$ 139 mm are used to close open-ended pipes in fitness products.
- Anchor caps are produced from polyethylene plastic material with LLDPE (Linear Low Density Polyethylene) injection method.
- It is resistant to UV rays and is designed not to harm the user.
- It is produced as double-walled and assembled with screwing system.
- The upper part of the main carrier body is closed with a pipe cover made of polyethylene material by injection method.
- The moving parts connected to the main body are manufactured from special twisted metal material with a wall thickness of at least  $\text{Ø}$  60 mm and 2.5-3 mm.
- Two 6006 2RS bearings are used in the starting moving parts.
- The joint connection pipes in the movable section of the walking system are manufactured from  $\text{Ø}$  60 mm and 2.5-3 mm thick pipes with a special twist.
- In order to prevent weld breaks and one-sided loading, the joints are manufactured to be connected from both sides of the 140 mm pipe.
- Foot pedals produced by injection method from fiber-mixed polyethylene material will be used in the foot part and foot pedals are mounted by welding a 5 mm thick support sheet underneath.
- The Shaped Handles are manufactured from  $\text{Ø}$  42 mm pipe with special twist and welded to the carrier body pipes and are reinforced with flag sheet in order to increase its durability.
- The main body flashes are manufactured by laser cutting from ST37 sheet metal with a thickness of 8 mm and a size of 280x280 mm.

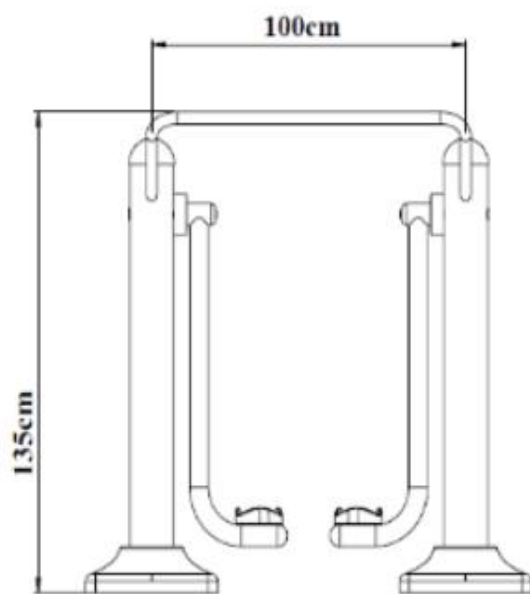
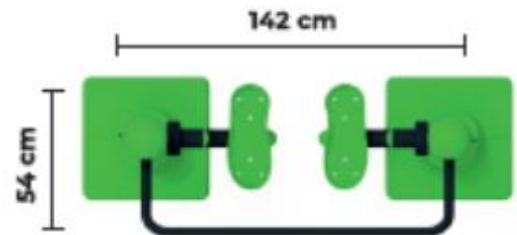
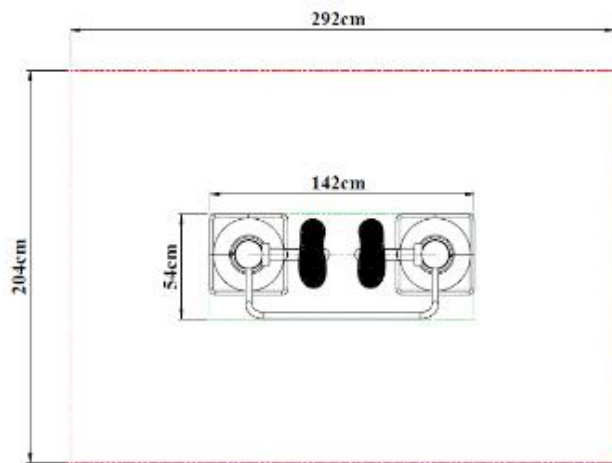

<b>Dimensions</b>	Width	54 cm
	Length	142 cm
	Height	135 cm

## Body-Building Equipment

- The product is produced in the form of three stations.
- There are one leg strengthening, one pull-up and one abdominal training station in the product.
- Anchor plugs with a diameter of Ø139 mm are used to close open-ended pipes in fitness products.
- Anchor caps are produced from polyethylene plastic material with LLDPE (Linear Low Density Polyethylene) injection method.
- It is resistant to UV rays and is designed not to harm the user.
- It is produced as double-walled and assembled with screwing system.
- Carrier pipes are manufactured from pipes with Ø 139 mm, wall thickness of 2.5-3 mm and a length of at least min 1890 mm.
- The moving parts connected to the main body are at least Ø 60 mm and 2.5-3 mm wall thickness.
- The pull-up tool hanger handles and armrest support pipe are manufactured from Ø 60 mm 2.5-3 mm wall thickness pipe specially bent.
- The components connected to the body are mounted with a 5 mm thick 140 connection clamp.
- 2 pcs 6205 2RS Bearings are used in the three Movable U-joint hubs.
- The movable weight part in the Vertical Leg reinforcement station is made of Ø60 mm filled metal material.
- The seat, backrests and armrest plastics are made of self-colored polyethylene material.
- The upper part of the main carrier pipe is closed with a plastic plug.
- Colored rubber pullers are attached to all handle places on the product in such a way that they fit tightly.
- The main body flanges are manufactured from ST37 sheet with a thickness of 8 mm and a size of 280x280 mm by laser cutting and are reinforced with flag sheets with a thickness of 5 mm in order to increase their strength.

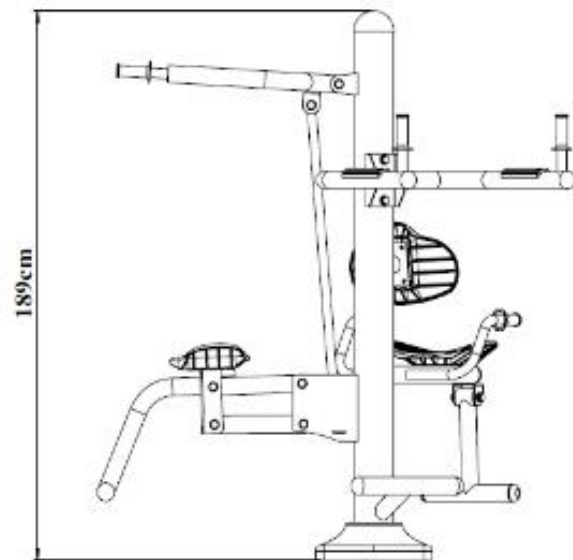
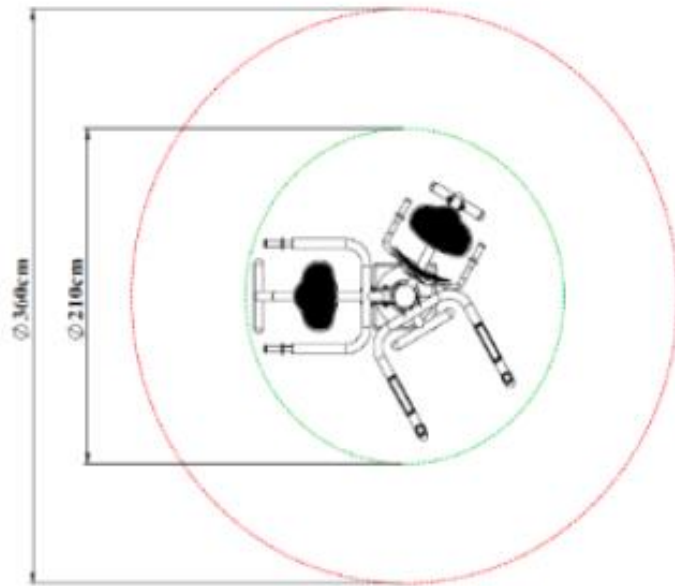

<b>Dimensions</b>	Width	210 cm
	Length	210 cm
	Height	189 cm

## Spare Parts

### Polyethylene Handle

- It is manufactured to cover the main pipe from the top and enable the user to hold it by hand.
- Polyethylene handles are produced from polyethylene plastic material with LLDPE (Linear Low Density Polyethylene) inflation method.



### Fitness Foot Disk

- It is produced in footsteps and in appropriate strength.
- Foot pedal is produced from polyethylene plastic material mixed with glass fiber by LLDPE (Linear Low Density Polyethylene) injection method.
- There are sets on it to prevent the feet from slipping.



### Bicycle Pedal

- Fitness pedal is produced from polyethylene plastic material with LLDPE (Linear Low Density Polyethylene) injection method.

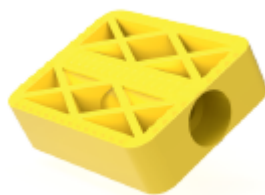

## **Fitness Seat**

- The seat is produced from polyethylene plastic material mixed with glass fiber by LLDPE (Linear Low Density Polyethylene) injection method.
- Fitness seat; It is produced to prevent sliding backwards, to the right and to the left.



## **Fitness Backrest and Seat**

- The seat is manufactured from polyethylene plastic material by LLDPE (Linear Low Density Polyethylene) injection method.
- It is produced to be used on seats and backrests.



## **Fitness Handle**

- Handpieces are manufactured from polyethylene plastic material LLDPE (Linear Low Density Polyethylene) injection method so that it can be held by hand and fits tightly to 33 mm pipe.

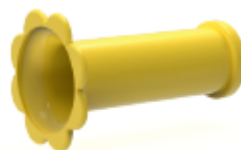



## **Fitness Hand Disk**

- The arm turning disc is designed and produced in a way that allows it to be used in the arm turning parts of the sports equipment and is robust.
- The seat and backrest are produced from polyethylene plastic material mixed with glass fiber by LLDPE (Linear Low Density Polyethylene) injection method.
- It has a spinning top that will make it easier to hold on its front surface and circular reliefs on the entire surface.
- Connection plate slot's back surface 4 pieces of m8 nuts are placed inside.



## **Fitness Anchorage Cover**

- Anchorage caps measuring  $\text{Ø } 139 \text{ mm}$  are used to cover open-ended pipes in children's playgrounds, and fitness equipments.
- Anchor caps are produced from polythene plastic material for indoor and outdoor use.
- It is resistant to UV lights and is designed not to harm the user.
- It is manufactured as double-walled and assembled with a screwing system.
- Anchor caps are produced from polyethylene plastic material mixed with glass fiber by LLDPE (Linear Low Density Polyethylene) inflation method.



## Fitness Right and Left Stand

- In the foot press section, there are 2 foot pedals produced from fiber mixed polyethylene material by injection printing method.
- The foot will be patterned to prevent it from slipping, the footrest is fixed to the 5 mm thick sheet metal.



## Bolts, Nuts and Washers

- The fasteners (bolts, washers, and nuts) used in-game systems are produced as Geomet B321 Plus or galvanized coating to protect them against corrosion.
- There are no nut and bolt protrusions anywhere in the playset.
- Except for the camber head nut within the playgroup, all nuts are produced with fiber.

