







PT-100



						
Age range 3+	Number of Users 10	Free Fall Height 1,5m	Height 4,22 m	Assemble Area 59m ²	Sitting Area 6,94 m*8,49 m	Safety Area 9,44 m*10,99 m

PRODUCT TREE

HOUSE ROOF	2	Piece
H:150 STRAIGHT SLIDE	1	Piece
H:150 SPIRAL SLIDE	1	Piece
H:100 STRAIGHT SLIDE	1	Piece
HAT FIGURED SLIDE ENTRY	1	Piece
WOODEN FIGURED SLIDE ENTRY	1	Piece
SPIRAL SLIDE ENTRY	1	Piece
LION FIGURED PANEL	1	Piece
DUCK FIGURED PANEL	1	Piece
PALM TREE	1	Piece
WOODPECKER FIGURE	1	Piece
H:100 CATERPILLAR STAIRS	1	Piece
H:100 FIGURED TUBE SLIDE	1	Piece
116 x 116 SQUARE PLATFORM	3	Piece
60 x 90 SPIRAL SLIDE PLATFORM	1	Piece
ANCHORAGE COVER	10	Piece
SCREW HIDING	30	Piece
PLASTIC CLAMP WITH STRAIGHT CONNECTION PART	26	Piece
H:50 INNER STAIRS	1	Piece
275 CM TOWER PIPE	2	Piece
285 CM TOWER PIPE	4	Piece
335 CM TOWER PIPE	4	Piece
180 CM SPIRAL INNER PIPE	1	Piece
Ø27 PANEL INNER PIPE	7	Piece
H:100 MUSHROOM CLIMBING	1	Piece
ATTACHED CURVED PULL UP CLIMBING	1	Set
H:100 TUBE PASSING	1	Piece

TECHNICAL DRAWING

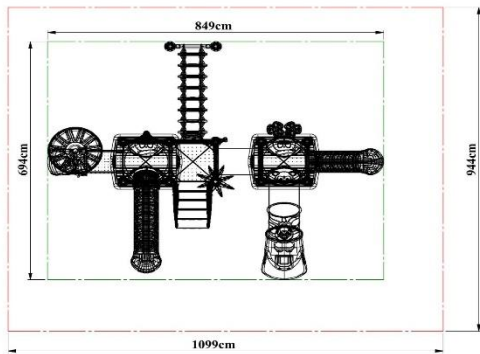
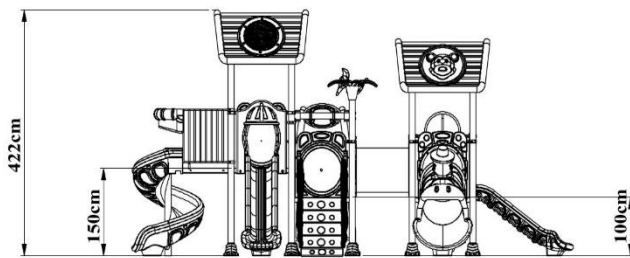

Load-bearing Construction

- Tower, slide, roof, ladder, railing, etc. The main columns that will carry the playgroup elements are manufactured from industrial pipes with a diameter of 114 mm and a wall thickness of min. 2 mm.
- The open top parts of the 114 mm diameter industrial pipes are closed and riveted with self-colored plastic pipe plugs shaped with injection molds in the form of a hemisphere with a wall thickness of 4-6 mm, detailed to prevent corrosion caused by water and moisture.

Polyethylene Products

- The raw material of polyethylene materials to be used in playgrounds is low density linear polyethylene.
- Original raw materials that do not contain any chemicals that may harm children's health and that have EN 1176-1.3 certificate are used.
- In order to prevent electrification, an anti-static agent is added to the polyethylene.
- There is no zinc in the paints used in the polyethylene raw material and the light sensitivity is between 6-8 scales.
- In polyethylene materials, the thickness is at least 5 mm in areas where there is friction and pressure.

Electrostatic Paint

- After all metal parts are manufactured, they are immersed in an iron phosphate bath with 1% concentration at 50 degrees for 15 minutes after rinsing in the dust and degreasing bath with 5% concentration at 70 degrees for 10 minutes.
- Afterward, it is rinsed with clean water again and drying processes are carried out.
- Before the static paint process, sanding is applied in a way to prevent rusting, which may be caused by dust and particles that can settle on the metal parts as a result of air circulation during the drying phase during the resting period.
- After this stage, the material is covered with polyester-based powder paint with a thickness of 60-80 microns, which prevents heating (color fading) in the sun, and then it is heated in an oven at a temperature of at least 200-220 degrees for 10 minutes, and the painting process is completed.

Pipes

- Tower pipes; It is manufactured from SDM pipe with a height of 275 cm, 285 cm, 335 cm a diameter of 114 mm, and a wall thickness of min. 2 mm.
- The tower pipes are produced in one piece and perfectly, from horizontal and vertical pipes in length cut according to the determined heights, with a minimum of 2250 mm.
- Pipes with seam marks on the surface are not used in production.
- Adding the length of the pipes, welding, etc. is not extended by the procedure.
- In order to prevent water, moisture, and foreign matter from entering the upper parts of these pipes, colored plastic pipe plugs produced by the injection method are fixed and closed to the pipes with a riveting system.
- The connection points of the pipes with the concrete floor are joined by the sheet metal flange welding method with the size of 20*20*6 mm.
- Connection of the Tower Pipes with the platform the half-moon-shaped ears welded according to the platform size, produced from 6 mm wall thickness, are welded to the pipes and these ears are connected to the platform with the screwing system by means of galvanized bolts and nuts.
- A polyester-based electrostatic powder paint coating process is performed and it is baked in a 200°C oven for 20 minutes.
- Tower pipes are closed with anchor caps produced by injection after assembly.
- 100 cm high, Ø27 elektrostatic paint panel inner pipe is used.



Dimensions	Diameter	Ø 114 mm
	Wall Thickness	Min. 2 mm

116x116 Square Platform

- The platform is manufactured from perforated sheet metal with a minimum size of 116 cm x 116 cm x 8 cm and a minimum wall thickness of 1.5 mm-2 mm.
- Flat designed surface; It is designed to prevent slipping and not allow water retention.
- In the middle of the platform, support sheets are welded to the lower part in order to prevent the sheet from flexing.
- The corners of the platform are manufactured in the form of a quarter circle, enclosing the 114 mm pipe.
- Before the coating process, the sheets are washed with special chemicals, cleared of oil and dirt that will prevent the coating on them, and then coated with the priming method.
- After the priming process, the upper surface of the platform is hot-dip method with an anti-static material mixture with a hardness of -60 ± 5 share A, a density of 1 gr/cm^3 , minimum kgf/cm^2 breaking strength, 650-700% breaking elongation, and 100 m^3 (max) abrasion. PVC (Plastisol) coating is made.
- PVC thickness is produced at a minimum of 2 mm at each point.

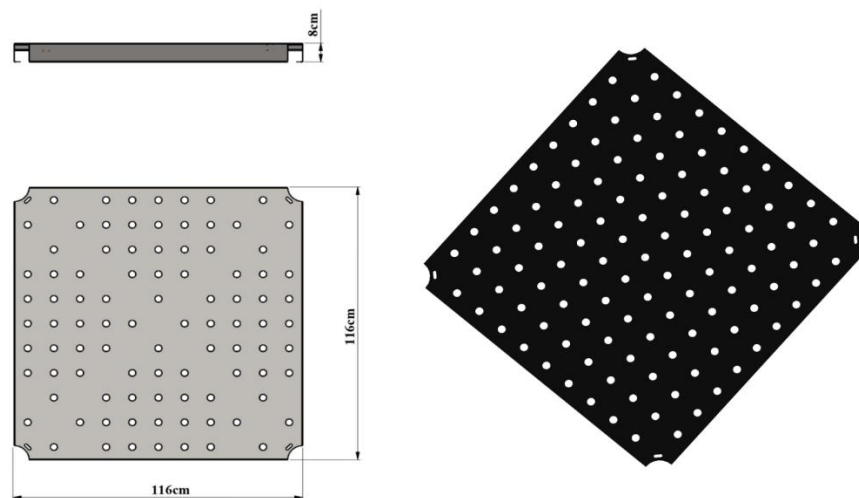

Dimensions	Platform Dimensions	116*116 cm
	Sheet Thickness	2 mm - 8 cm

60x90 Spiral Extension Platform

- The platform is manufactured from perforated sheet metal with a minimum dimension of 60 cm x 90 cm x 8 cm and a minimum wall thickness of 1.5 mm-2 mm.
- Flat designed surface; It is designed to prevent slipping and not allow water retention.
- In the middle of the platform, support sheets are welded to the lower part in order to prevent the sheet from flexing.
- The corners of the platform are manufactured in the form of a quarter circle, enclosing the 114 mm pipe.
- Before the coating process, the sheets are washed with special chemicals, cleared of oil and dirt that will prevent the coating on them, and then coated with the priming method.
- After the priming process, the upper surface of the platform is hot-dip method with an anti-static material mixture with a hardness of -60 ± 5 share A, a density of 1 gr/cm^3 , minimum kgf/cm^2 breaking strength, 650-700% breaking elongation, and 100 m^3 (max) abrasion. PVC (Plastisol) coating is made.
- PVC thickness is produced at a minimum of 2 mm at each point.
- The platform is attached to the square platform by screwing and its assembly is provided.

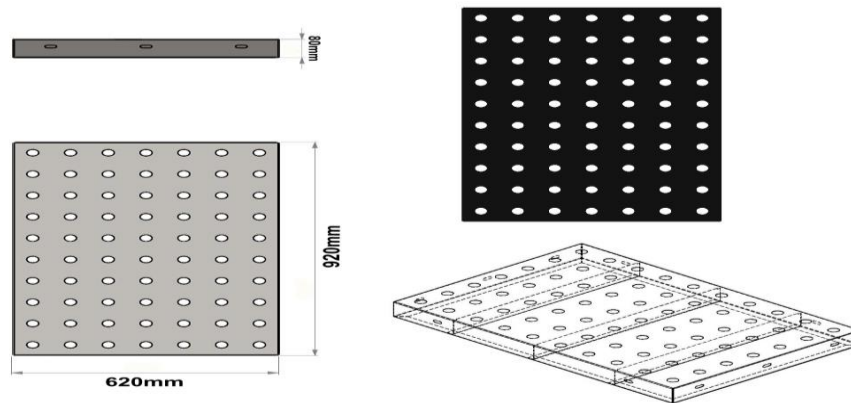

Dimensions	Platform Dimensions	60*90 cm
	Sheet Thickness	2 mm - 8 cm
Features	Plastisol Coated Platform	

Spiral Slide Metal Railing

- The edges of the stair railing are produced from a maximum of $\text{Ø } 27$ mm pipe, and the railings are produced from a minimum of $\text{Ø } 21$ mm pipes.
- Stair railings are painted with polyester-based electrostatic powder paint.
- The slide entrance railing is produced as a single piece of metal.
- The slide entry guardrail is connected to the carrier pole with the help of polyamide clamps with $\text{Ø}27$ mm pipes from the top.
- It is mounted on the platform with the help of galvanized bolts and nuts from the bottom.

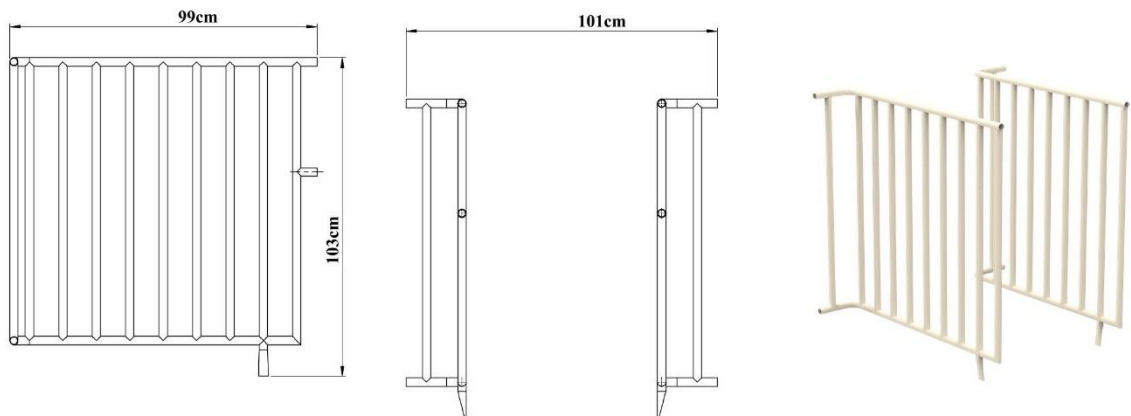

Dimensions	Outer Frame Tube	$\text{Ø } 27$ mm
	Frame Inner Tube	$\text{Ø } 21$ mm
	Minimum Distance Between Railings	88 mm

H:50 Inner Stair

- The ladder is manufactured in such a way that it can reach 50 cm elevation difference from the tower to the platform.
- Ladders are manufactured from $\text{Ø } 27 \text{ mm}$ pipe by bending the outer part and welding the pipe that will come to the 3 straight step parts to each other.
- It will be fixed to the $\text{Ø } 114 \text{ mm}$ pipes by screwing to the platform from the ears on the lower part by attaching the vertical mouth and clamp.
- Stairs will be painted with polyester-based electrostatic powder paint after the welding process is completed.

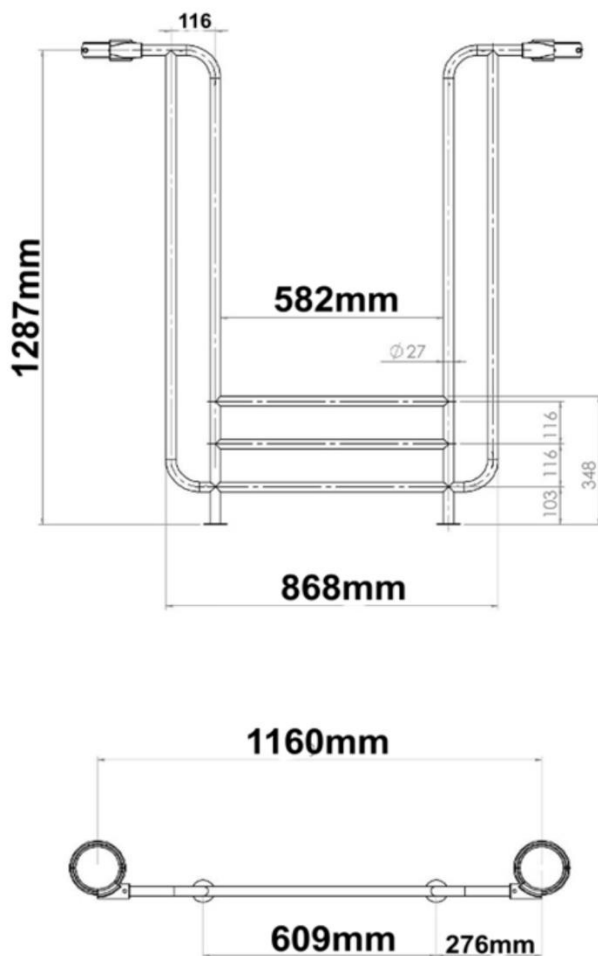

Dimensions	Platform Height	50 cm
Features	Electrostatic paint Stairs + Metal Railing	

H:100 Plastic Stair

- The stair is manufactured from self-colored polyethylene plastic material, LLDPE (Linear Low Density Polyethylene) rotation molding method, with a minimum of 4 steps, in a way that can reach 100 cm level difference from the ground to the platform.
- There are patterns designed for children on the stair railing.
- Stair railing is manufactured from self-colored polyethylene plastic material LLDPE (Linear Low Density Polyethylene) by rotation molding method.
- In order for the product surface to be smooth; Sandblasting is applied to the surface of the mold made of aluminum or equivalent material and it is produced by passing the Teflon coating process for surface brightness.

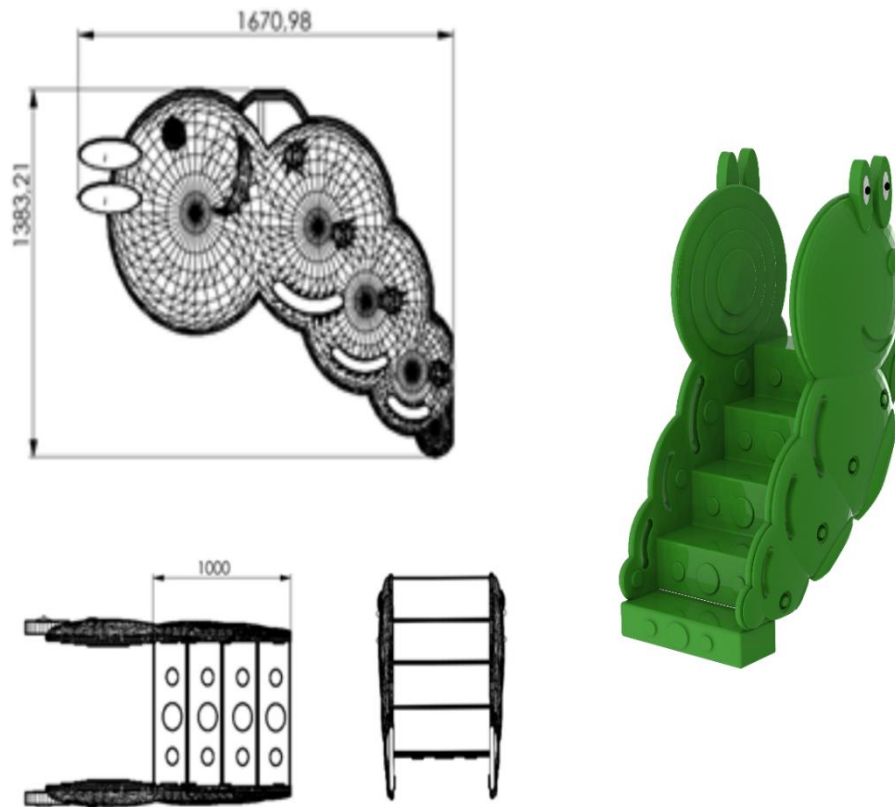

Dimensions	Platform Height	100 cm
	Railing Height	167 cm
	Railing Width	138 cm
Features	min. Weight	50 kg
	Raw materials	LLDPE

Spiral Slide Entrance

- It is manufactured from self-colored polyethylene plastic material as a one-piece and double-walled by rotation molding method with low density (LLDPE Linear Low-Density Polyethylene) designed to prevent falling into the slide entrances.
- In order for the product surface to be smooth; It is produced by sandblasting the surface of the mold made of aluminum or its equivalent material and undergoing a Teflon coating process for surface brightness.

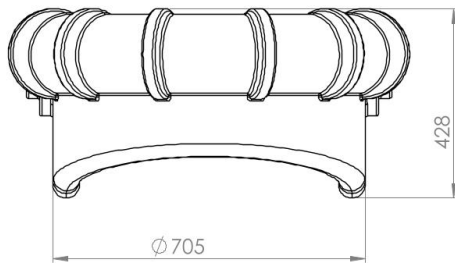
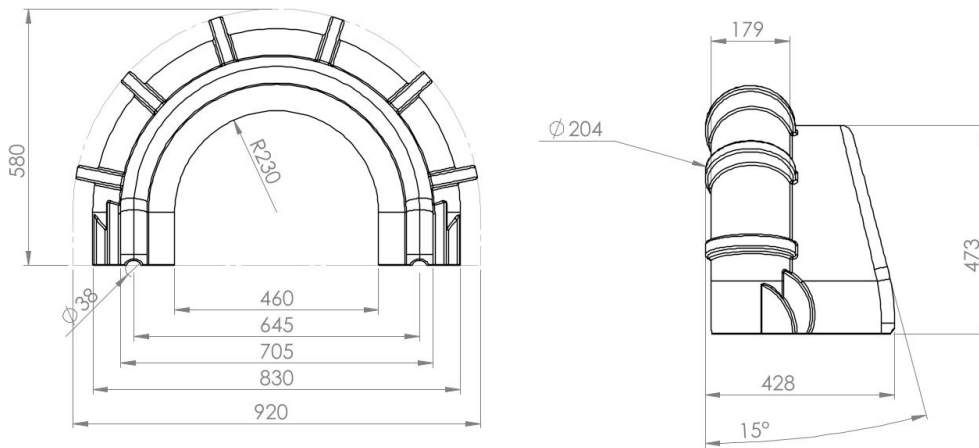

Dimensions	Length	58 cm
	Width	92 cm
	Input Width	46 cm
Features	Min. Weight	8 kg
	Raw material	LLDPE

Wooden Figured Straight Slide Entry

- It is manufactured from self-colored polyethylene plastic material as a one-piece and double-walled by rotation molding method with low density (LLDPE Linear Low-Density Polyethylene) designed to prevent falling into the slide entrances.
- Plastic clamps and vertical mouth connection apparatuses are attached to the $\text{\O} 27$ mm inner pipe ends attached to the slides, and the $\text{\O} 114$ mm tower is fixed to the pipes and screwed from the parts of the panels that sit on the platform.
- In order for the product surface to be smooth; It is produced by sandblasting the surface of the mold made of aluminum or its equivalent material and undergoing a Teflon coating process for surface brightness.

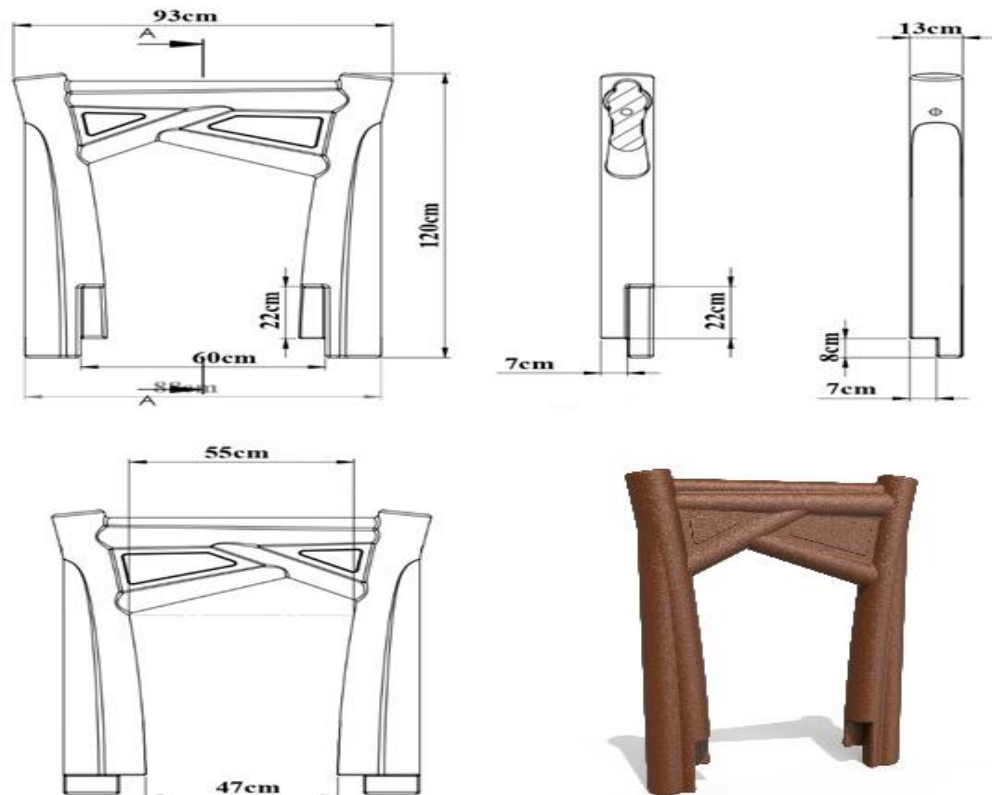

Dimensions	Length	120 cm
	Width	93cm
	Input Width	55 cm
Features	Min. Weight	8,5 kg
	Raw material	LLDPE

Flat Slide Entrance With Hat

- It is manufactured from self-colored polyethylene plastic material as a one-piece and double-walled by rotation molding method with low density (LLDPE Linear Low-Density Polyethylene) designed to prevent falling into the slide entrances.
- Plastic clamps and vertical mouth connection apparatuses are attached to the $\text{Ø } 27 \text{ mm}$ inner pipe ends attached to the slides, and the $\text{Ø } 114 \text{ mm}$ tower is fixed to the pipes and screwed from the parts of the panels that sit on the platform.
- In order for the product surface to be smooth; It is produced by sandblasting the surface of the mold made of aluminum or its equivalent material and undergoing a Teflon coating process for surface brightness.

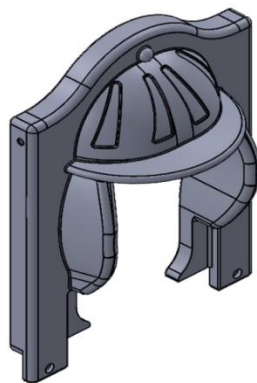
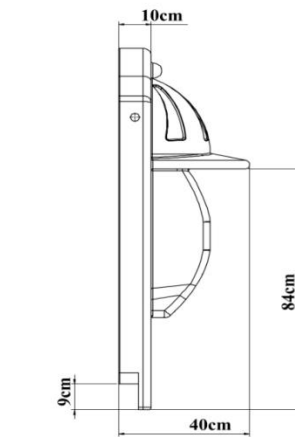
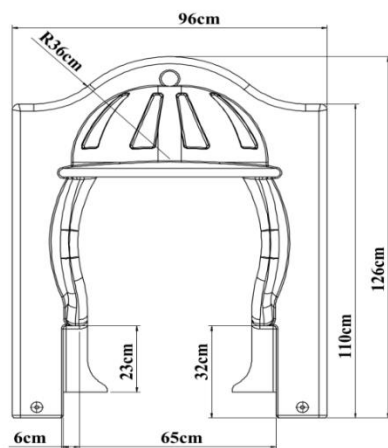

Dimensions	Height	126 cm
	Width	96 cm
	Panel thickness	40 cm
Features	Min Weight	8 kg
	Raw material	LLDPE

Duck Figured Panel

- Duck figured panels are manufactured from self-colored polyethylene LLDPE (Linear Low-Density Polyethylene) material as double-walled by rotation molding method.
- The Duck figured panels are fixed to the main construction with the help of a polyamide-based clamp system with pipes of 95x122 cm dimensions Ø, 27 mm diameter from the top.
- The dyestuffs used in coloring are suitable for child health.

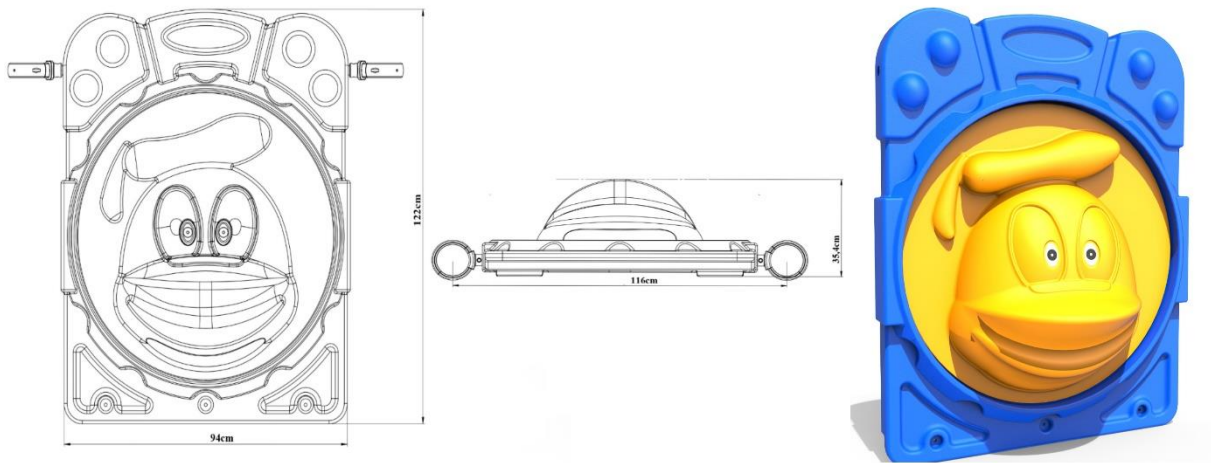

Dimensions	Height	122 cm
	Width	95 cm
	Panel thickness	35,4 cm
Features	Min Weight	12,5 kg
	Raw material	LLDPE

Lion Figured Panel

- Lion figured panels are manufactured from self-colored polyethylene LLDPE (Linear Low-Density Polyethylene) material as double-walled by rotation molding method.
- The Lion figured panels are fixed to the main construction with the help of a polyamide-based clamp system with 96x122 cm dimensions, Ø 27 mm diameter from the top.
- The dyestuffs used in coloring are suitable for child health.

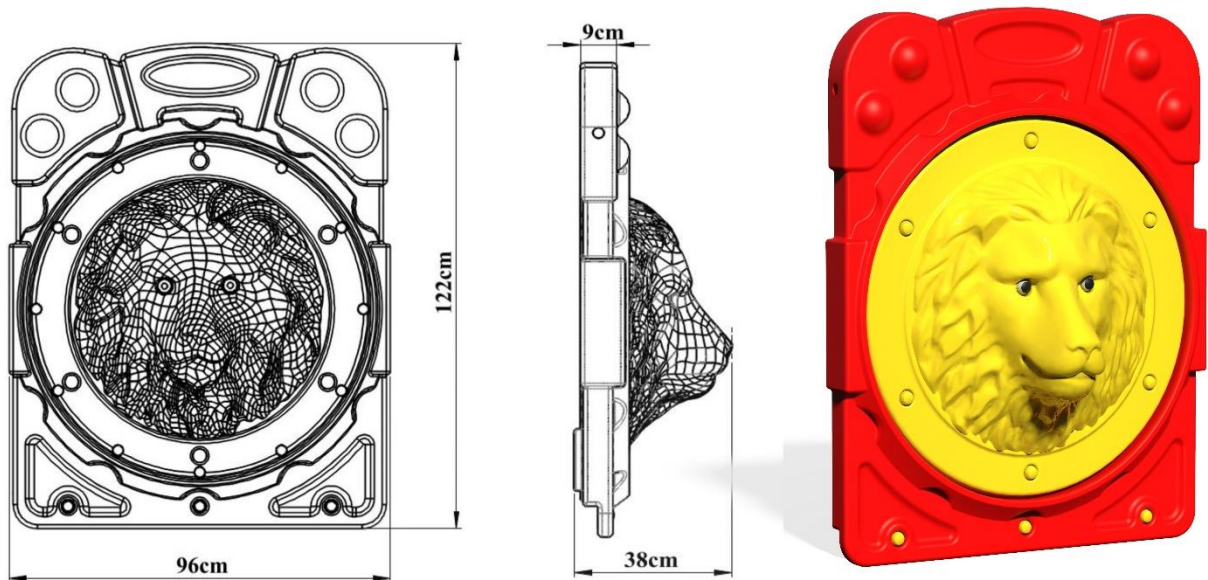

Dimensions	Height	122 cm
	Width	96 cm
	Panel thickness	38 cm
Features	Min Weight	13 kg
	Raw material	LLDPE

H:100 Straight Slide

- LLDPE (Linear Low-Density Polyethylene) made of self-colored polyethylene plastic material, which is designed to slide from a 100 cm high platform, has a minimum length of 2 meters, is produced in a single piece and double-walled form with a minimum weight of 22 kg.
- It is manufactured in such a way that the inner height dimension of the side protective corners of the slide is 17 cm, the width of the sliding surface is 40 cm, and the slope is 25-30 degrees.
- The slide is fixed to the ground with a metal apparatus from the anchorage point at the bottom of the slide's exit point.
- In order for the product surface to be smooth; Sandblasting is applied to the surface of the mold made of aluminum or its equivalent material, and it is produced by passing the Teflon coating process for surface brightness.
- A flat slide entrance panel is used to ensure safety at the slide entrance.
- LLDPE (Linear Low-Density Polyethylene) from self-colored polyethylene plastic material is produced in one piece by rotation molding method.
- Plastic clamps and vertical mouth connection apparatuses are attached to the \varnothing 27 mm inner pipe ends attached to the inside of the polyethylene flat slide entrance panels and fixed to the \varnothing 114 mm tower pipes.

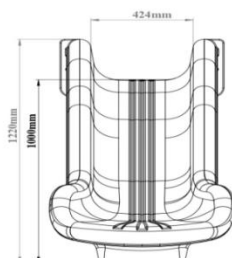
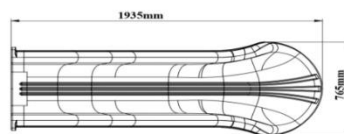

Dimensions	Platform Height	100 cm
	Side Wall Length	17 cm
	Slide Inner Width	40 cm
	Slide Length	210 cm
Features	Raw material	LLDPE
	Min. Slide Weight	22 kg

H: 150 Straight Slide

- LLDPE (Linear Low-Density Polyethylene) made of self-colored polyethylene plastic material, which is designed to slide from a 150 cm high platform, has a minimum length of 3 meters, is produced in a single piece and double-walled form with a minimum weight of 33 kg.
- It is manufactured in such a way that the inner height dimension of the side protective corners of the slide is 17 cm, the width of the sliding surface is 40 cm, and the slope is 25-30 degrees.
- The slide is fixed to the ground with a metal apparatus from the anchorage point at the bottom of the slide's exit point.
- In order for the product surface to be smooth; Sandblasting is applied to the surface of the mold made of aluminum or its equivalent material, and it is produced by passing the Teflon coating process for surface brightness.
- A flat slide entrance panel is used to ensure safety at the slide entrance.
- LLDPE (Linear Low-Density Polyethylene) from self-colored polyethylene plastic material is produced in one piece by rotation molding method.
- Plastic clamps and vertical mouth connection apparatuses are attached to the $\varnothing 27$ mm inner pipe ends attached to the inside of the polyethylene flat slide entrance panels and fixed to the $\varnothing 114$ mm tower pipes.

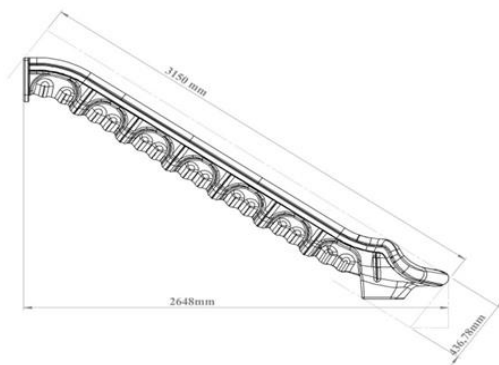
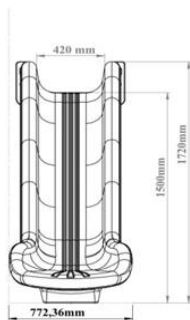

Dimensions	Platform Height	150 cm
	Side Wall Length	17 cm
	Slide Inner Width	40 cm
	Slide Length	315 cm
Features	Raw material	LLDPE
	Min. Slide Weight	33 kg

H:150 Spiral Slide

- It is produced from a single piece of polyethylene plastic material with a low-density LLDPE (Linear Low-Density Polyethylene) rotation molding method, which is spirally molded from a 150±10 cm high platform to a minimum Ø89 mm profile pipe in its center, in a self-colored form.
- It is manufactured in such a way that the inside height measure of the side protective corners of the slide is 17 cm, the width of the sliding surface is 40 cm, and the slope is 25-30 degrees.
- In order to ensure safety, metal spiral guardrails are used on both sides of the slide entrance, and a polyethylene entrance barrier with a minimum weight of 8 kg is used on the upper part.
- A 15*15*5 mm diameter flange is welded to the middle part of the slide, and it is fixed to the floor with an SDM pipe with a diameter of 89 mm, a length of 180 cm

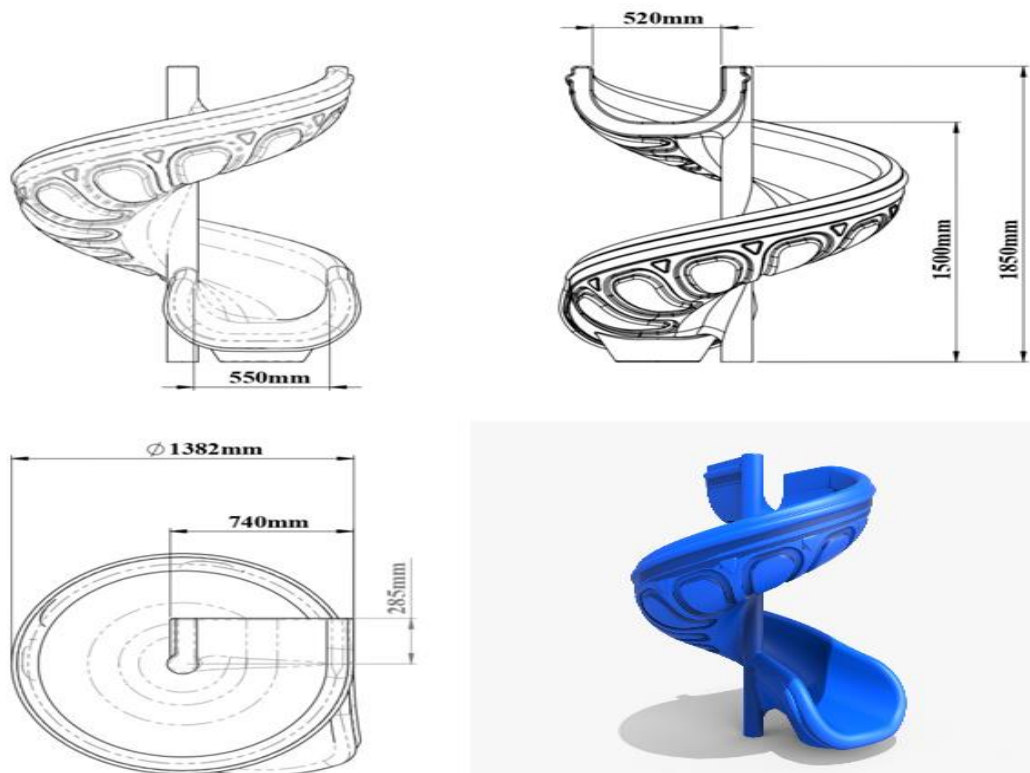

Dimensions	Platform Height	150 cm
	Side Wall Length	17 cm
	Slide Inner Width	40 cm
	Slide Length	185cm
Features	Raw material	LLDPE
	min. Slide Weight	38 kg

H:100 Figured Tube Slide

- H:100 figured tube slide with a minimum length of 3,46 m, designed to slide from a platform with a height of 100 cm; tube inlet, 1 pcs 35 degree tube elbow, 1 pcs 80 cm figured tube and figured tube outlet are manufactured from a total of 4 parts and from self-colored polyethylene plastic material LLDPE (Linear Low Density Polyethylene) rotation molding method.
- The product produced as disassembled; It is made a whole by assembling the given tube parts to each other according to the given angles.
- The slide is fixed to the ground with a metal apparatus from the anchorage point at the bottom of the slide's exit point.
- In order for the product surface to be smooth; Sandblasting is applied to the surface of the mold made of aluminum or its equivalent material, and it is produced by passing the Teflon coating process for surface brightness.

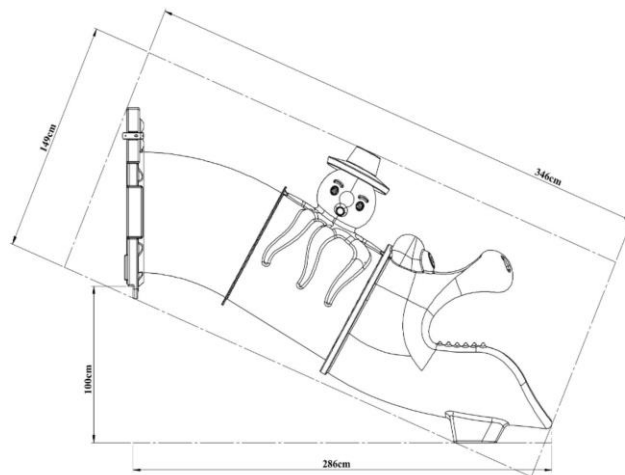

Dimensions	Platform Height	100 cm
	Tube Length	346 cm
	Panel Entry Diameter	75 cm
Features	Raw materials	LLDPE
	min. Slide Weight	74 kg

Tube Slide Entry

- It is manufactured from self-colored polyethylene plastic material as a one-piece and double-walled by rotation molding method with low density (LLDPE Linear Low-Density Polyethylene) designed to prevent falling into the slide entrances.
- Plastic clamps and vertical mouth connection apparatuses are attached to the Ø 27 mm inner pipe ends attached to the slides, and the Ø 114 mm tower is fixed to the pipes and screwed from the parts of the panels that sit on the platform.
- In order for the product surface to be smooth; It is produced by sandblasting the surface of the mold made of aluminum or its equivalent material and undergoing a Teflon coating process for surface brightness.

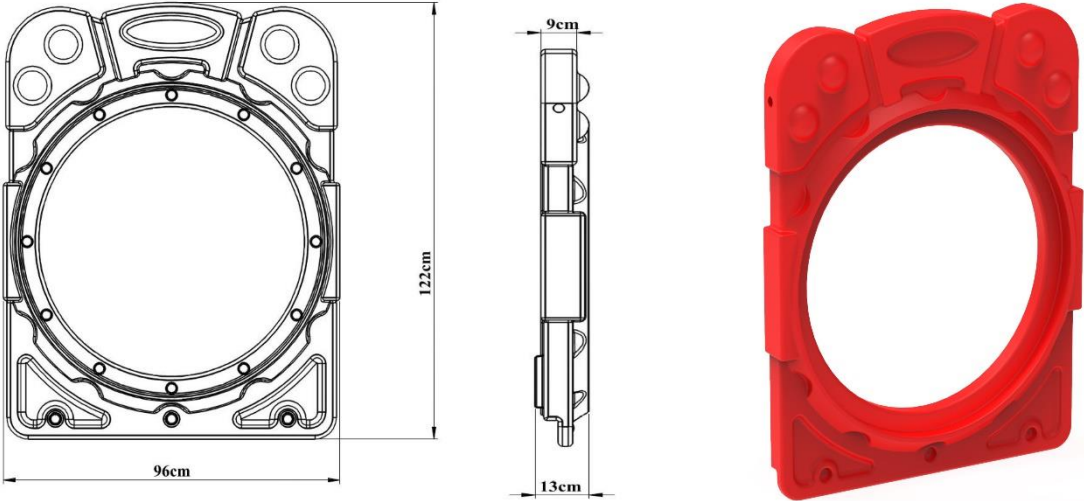

Dimensions	Length	122 cm
	Width	96 cm
	Input Width	75 cm
Features	Min. Weight	9 kg
	Raw material	LLDPE

Figured 80 Cm Tube

- 80 cm figured tubes forming tube slides are manufactured as a single piece from self-colored polyethylene plastic material, LLDPE (Linear Low Density Polyethylene) rotation molding method.
- Installation of the product is provided by screwing method.
- In order for the product surface to be smooth; Sandblasting is applied to the surface of the mold made of aluminum or its equivalent material, and it is produced by passing the Teflon coating process for surface brightness.

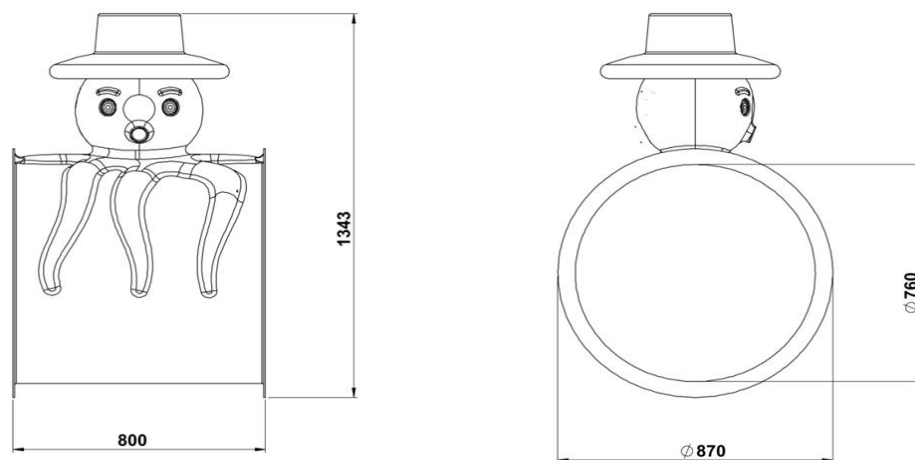

Dimensions	Tube Length	80 cm
	Tube Diameter	87 cm
Features	Minimum Weight	19 kg
	Raw materials	LLDPE

35° Tube

- The 35° tubes that make up the tube slides are manufactured from self-colored polyethylene plastic material, LLDPE (Linear Low Density Polyethylene) by rotation molding method as a single piece, providing an inclination of 35 degrees.
- Installation of the product is provided by screwing method.
- In order for the product surface to be smooth; Sandblasting is applied to the surface of the mold made of aluminum or its equivalent material, and it is produced by passing the Teflon coating process for surface brightness.

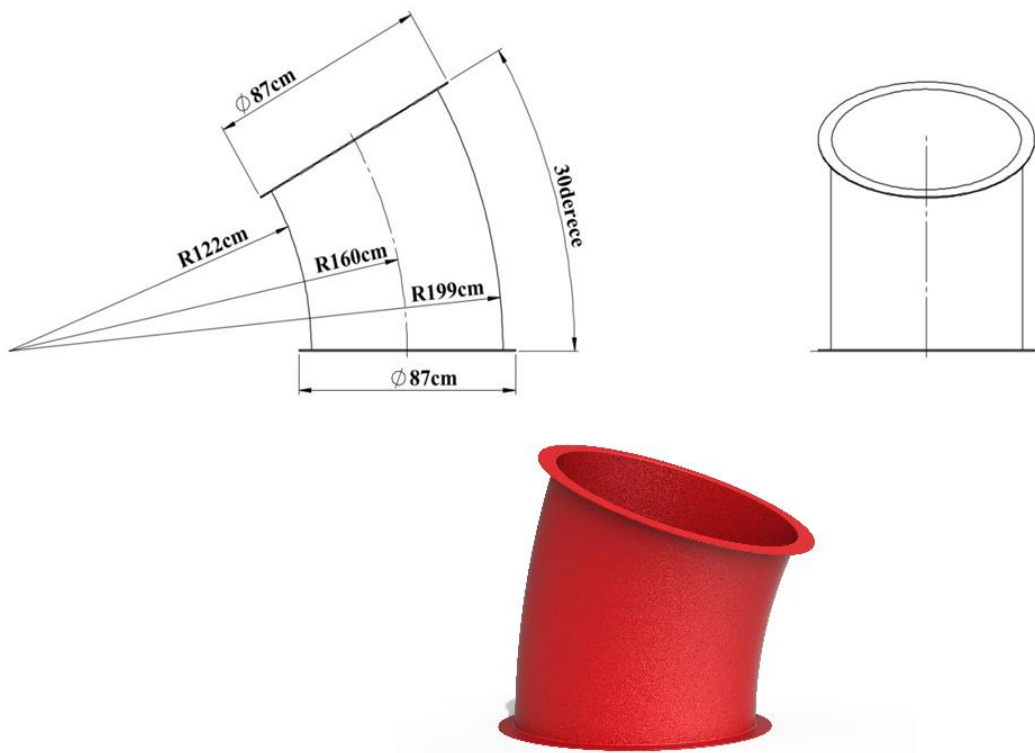

Dimensions	Tube Angle	35°
	Tube Diameter	87 cm
Features	Minimum Weight	17 kg
	Raw materials	LLDPE

Tube Output

- The tube outlet forming the tube slides is manufactured as a single piece by rotation molding method from self-colored polyethylene plastic material, LLDPE (Linear Low Density Polyethylene) so that the child can come out of the play element safely.
- Installation of the product is provided by screwing method.
- In order for the product surface to be smooth; Sandblasting is applied to the surface of the mold made of aluminum or its equivalent material, and it is produced by passing the Teflon coating process for surface brightness.

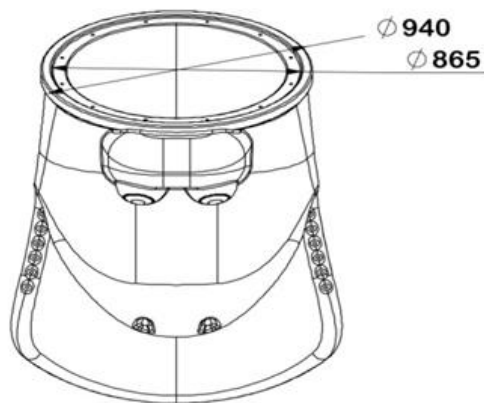
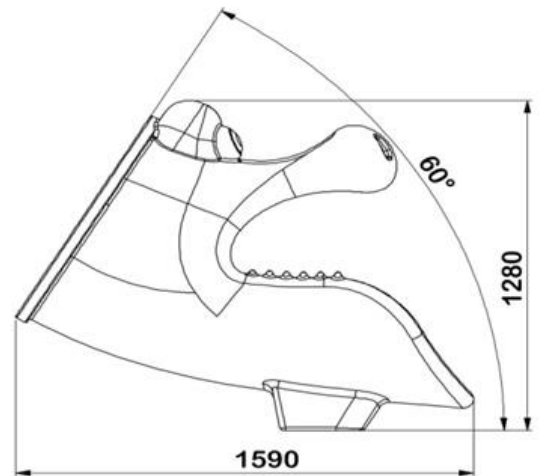
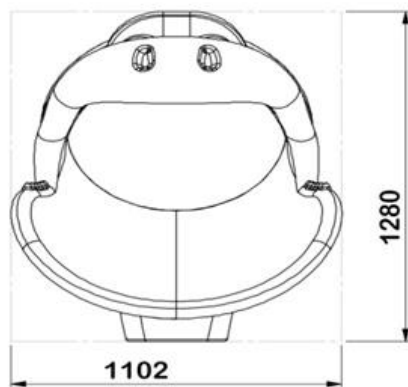

Dimensions	Tube Output Length	160 cm
	Tube Outlet Diameter	86 cm
Features	Minimum Weight	25 kg
	Raw materials	LLDPE

100 Cm Tube Passage

- H:100 tube passage with a minimum length of 1 m, designed to allow passage between two platforms; It is manufactured from 3 parts, 2 pcs tube inlets and 1 pcs 110 degree tube, and from self-colored polyethylene plastic material, LLDPE (Linear Low Density Polyethylene) rotation molding method.
- Plastic clamps and vertical mouth connection apparatuses are attached to the ends of $\text{Ø } 27$ inner pipes attached to the tube passages, and 114 towers are fixed to the pipes and screwed from the parts of the panels that sit on the platform.
- The product produced as disassembled; It is made a whole by assembling the given tube parts to each other according to the given angles.
- In order for the product surface to be smooth; Sandblasting is applied to the surface of the mold made of aluminum or its equivalent material, and it is produced by passing the Teflon coating process for surface brightness.

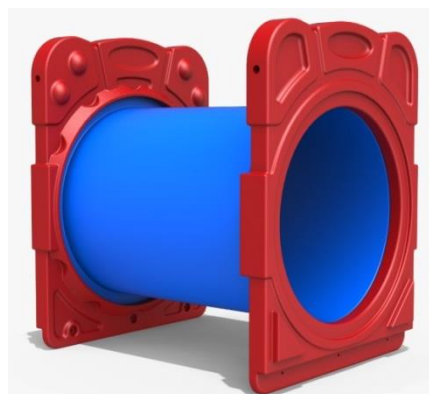
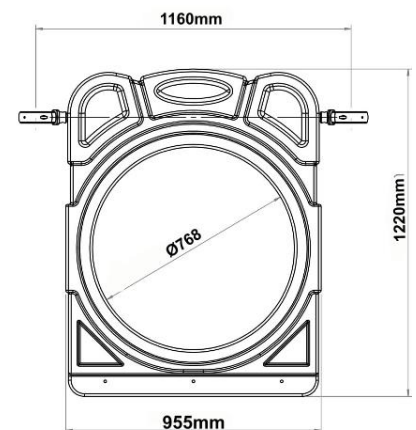
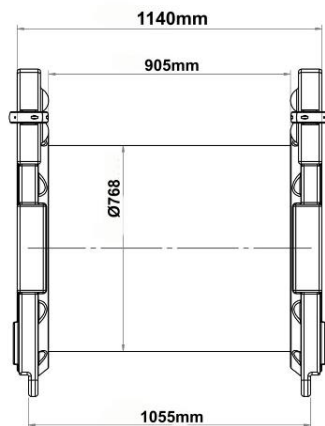

Dimensions	Tube Passage Length	124 cm
	Panel Entry Diameter	75 cm
Features	Min. Weight	42 kg
	Raw material	LLDPE

House Roof

- The house roof is manufactured from polyethylene plastic material, LLDPE (Linear Low-Density Polyethylene) with a minimum height of 89 cm, by rotation molding method, in two parts as body and upper apparatus, in self-color.
- In accordance with TS EN 1176-1, when measuring on the platform, the height between the platform and the roof is at least 1800 mm.
- The house roof is manufactured to be directly connected to the main construction.
- No connecting element is used in between.
- The roof of the house is completed by mounting 2 large figures on the side surfaces with screws.

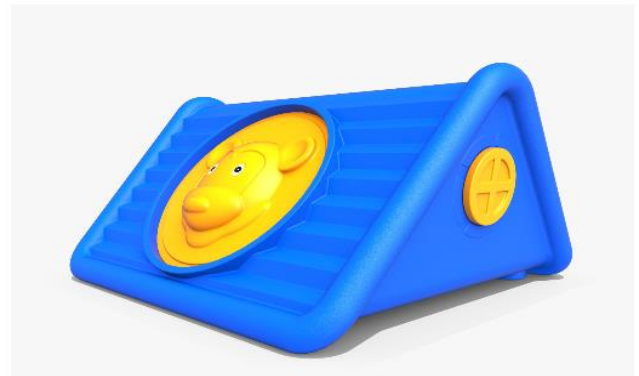
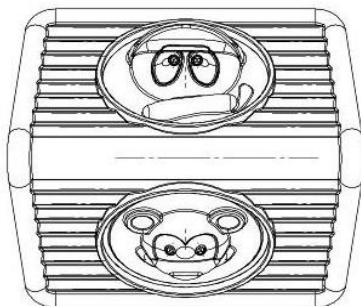
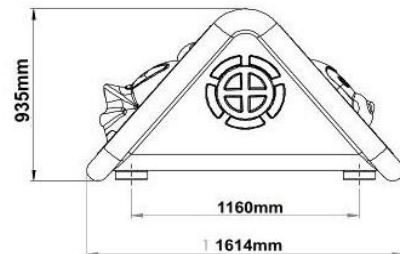
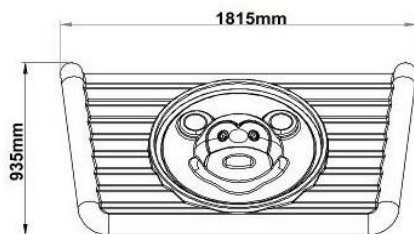

Dimensions	Size	161 cm
	Width	181 cm
	Min. House Roof Height	89 cm
Features	Min. House Roof Weight	37 kg
	Raw material	LLDPE

Woodpecker Figure

- The woodpecker figure is used to add visuality to playgroups.
- It is produced from polyethylene material suitable for indoor and outdoor use in accordance with 114 mm pipe.
- It is resistant to UV lights and is designed not to harm the user.
- The woodpecker figure weighs 2 kg.



Palm Figure

- The palm figure is used to add visuality to playgroups.
- It is produced from polyethylene material suitable for indoor and outdoor use in accordance with 114 mm pipe.
- It is resistant to UV lights and is designed not to harm the user.
- The palm figure weighs 8 kg.

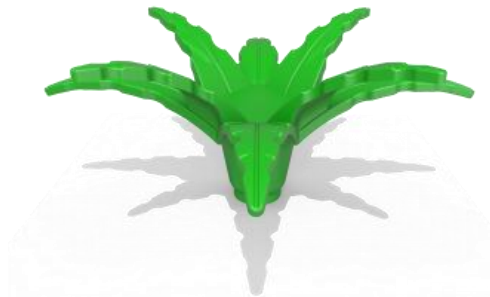

H:100 Mushroom Climbing

- Mushroom climbing is manufactured in such a way that it can reach 100 cm level difference from the ground to the platform.
- Stairs are manufactured from Ø32 pipe by twisting the outer part, in the form of 4 steps, with a climbing difference of 26 cm between them, assembling a daisy figure and climbing up to the platform in the form of a ladder.
- Vertical mouth and clamp are attached to the Ø114 pipes, and the ears on the bottom part are screwed to the platform at the bottom.
- Stairs are painted with polyester-based electrostatic powder paint after the welding process is completed.

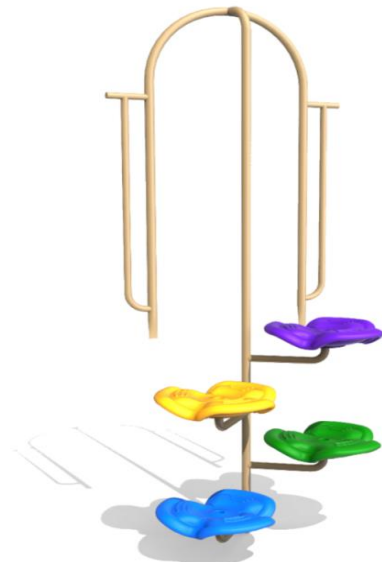
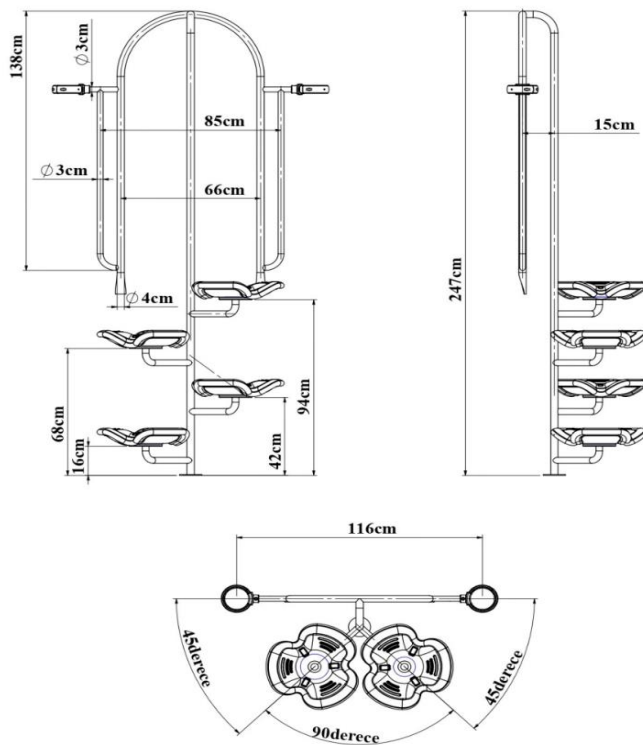

Dimensions	Platform Length	100 cm
	Climb Length	100 cm
	Min Mushroom Climbing Weight	22,5 kg
	Digit Distance	26 cm

Attached Curved Pull Up Climbing

- The cutting points of the horizontal and vertical pipes from the SDM pipe with a diameter of 114 mm are connected to each other with doetail metal clamps with a minimum wall thickness of 3 mm to form a right angle.
- The open parts of the Ø 114 mm diameter SDM pipes are detailed to prevent rusting caused by water and moisture, shaped with hemispherical injection molds, sealed with self-colored plastic plugs and riveted.
- Attached curved pull-up climbing step section is formed by using Ø 32 mm pipes between 2 pcs side pillars minimum height of 2,5 m Ø 114 mm pipes.
- A pull-up climbing figure made of 8 pieces of self-colored polyethylene plastic material LLDPE (Linear Low Density Polyethylene) is used in this pull-up climbing.
- These pull-up climbing figures are mounted by attaching them to the upper pipes with a diameter of Ø 32 mm.
- After the clamp connection is made, there are no protrusions or sharp corners that may cause injury anywhere.
- The parts are painted by baking with polyester-based electrostatic powder coating.

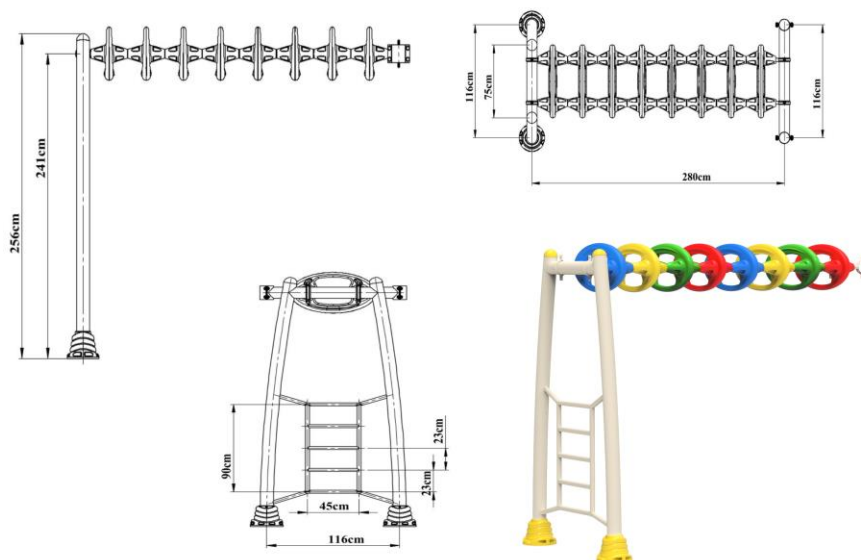

Dimensions	Side Pipe Length	256 cm
	Intermediate Deceleration Length	280 cm
	Side Climbing Pipe Thickness	27mm-32 mm

Ø 114 Hat Plug

- The cap plug is used to close open-ended pipes in children's playgroups, seesaws, swings, and other products.
- The cap plug is manufactured from polyethylene material for indoor and outdoor use.
- The product is resistant to UV lights.
- Its design is oval in a way that does not harm the user.
- It grasps the pipe with its 114 mm double-walled inlet and is easy to install.

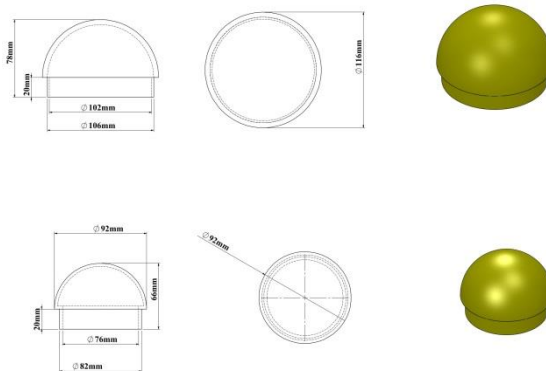

Ø 114 Anchor Cover

- Anchor caps measuring 114 mm are used to cover open-ended pipes in children's playgrounds, seesaws, swings, and other products.
- Anchor caps are produced from polythene plastic material for indoor and outdoor use.
- It is resistant to UV lights and is designed not to harm the user.
- It is manufactured as double-walled and assembled with a screwing system.

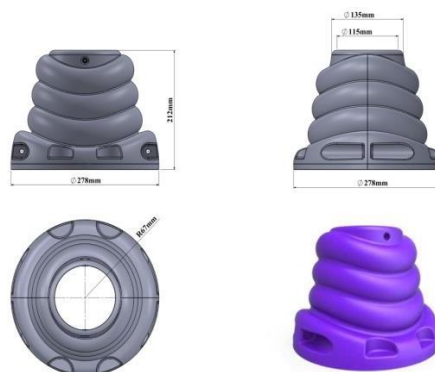

Screw Concealment

- Screw hides are used in all playgroups to prevent possible accidents and injuries.
- Screw hides; It provides an aesthetic appearance to playgroups and parking elements by allowing mounting elements such as screws and nuts to be hidden.
- Screw closures are produced from polythene plastic material by injection method, suitable for indoor and outdoor use.
- It is resistant to UV lights and is designed not to harm the user.

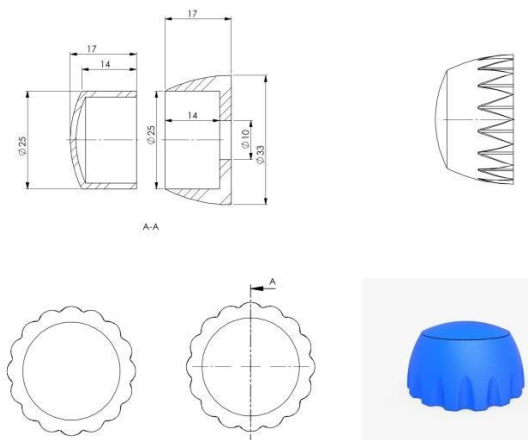

Connectors

Ø 114 Plastic Clamps

- Plastic clamps, board on the playgroup, slide entrance, railings, etc. It enables the elements to be mounted on the carrier system with a diameter of 114 mm.
- Clamps are manufactured from fibrous polyamide raw material by injection method.
- The clamp is designed in accordance with the inner diameter 114 mm pipe.
- It does not rotate on the pipe surface when tightened.
- After the clamp is connected, there are no protrusions or sharp corners that may cause injury in any part of the clamp.
- It can be produced in the desired color.

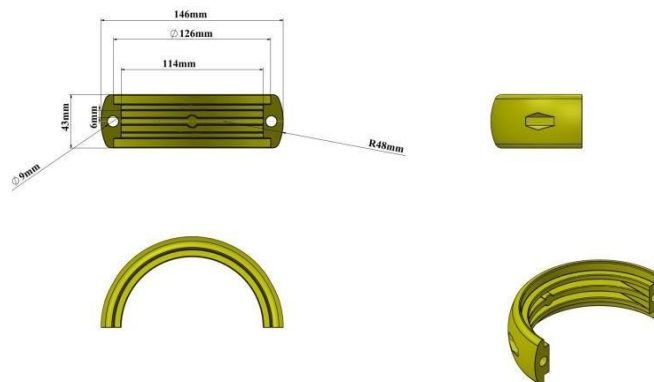

Ø114 Perpendicular Mouth

- Upright mouth, curved mouth, and platform wedge apparatus are used in the assembly of various playgrounds and sports equipment.
- It is produced from polyethylene material suitable for 114 mm pipe, suitable for indoor and outdoor use.
- The product is resistant to UV lights.
- Its design is in a structure that will not harm the user.
- It can be produced in desired colors.

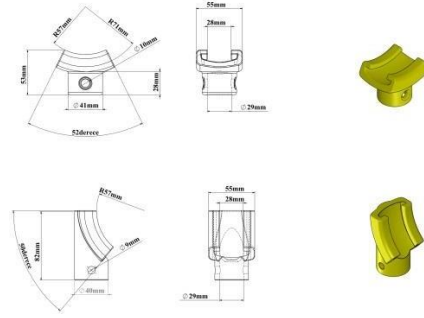

Bolts, Nuts and Washers

- The fasteners (bolts, washers, and nuts) used in-game systems are produced as GeometB321 Plus or galvanized coating to protect them against corrosion.
- There are no nut and bolt protrusions anywhere in the playset.
- Except for the camber head nut within the playgroup, all nuts are produced with fiber.

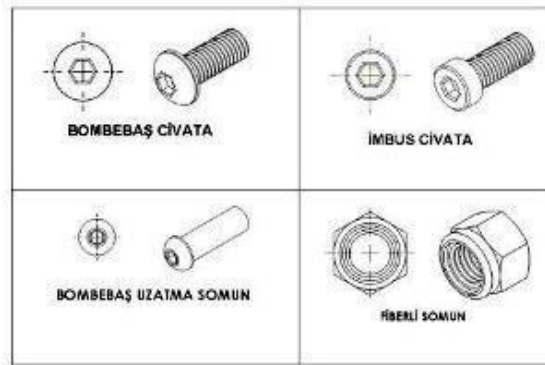

Metal Doetail Clamp

- Doetail clamp made of 3 mm DKP sheet is used in the swing and climbing connections.
- The inner diameter of the clamp, which consists of 2 parts, is designed in accordance with the carrier pipe with a diameter of $\text{Ø}114$ mm and is connected to the carrier H on one side and to the horizontal carrier pipe on the other.
- When it is connected to the pipe and its bolts are tightened, there is no gap and play.
- After the clamp connection is made, there are no protrusions or sharp corners that may cause injury anywhere.
- Bolt connections are designed to not loosen on their own.
- The parts are painted with polyester-based electrostatic powder oven paint by baking.

