

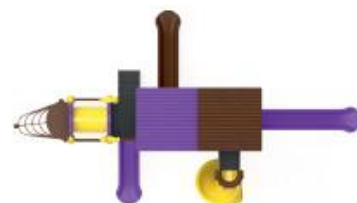

PT-124



Age range
3+



Number of Users
9



Free Fall Height
2m



Height
4,35 m



Assemble Area
38m²



Sitting Area
5,73 m* 6,50 m



Safety Area
8,73 m* 8,50 m

PRODUCT TREE

TRAIN ROOF	2	Piece
H:100 STRAIGHT SLIDE	1	Piece
H:150 STRAIGHT SLIDE	1	Piece
H:200 SPIRAL SLIDE	1	Piece
H:200 STRAIGHT SLIDE	1	Piece
230 CM SPIRAL INNER PIPE	1	Piece
HAT FIGURED SLIDE ENTRY	1	Piece
SPIRAL SLIDE ENTRY	1	Piece
Ø114 HAT PLUG	2	Piece
WOODEN FIGURED SLIDE ENTRY	2	Piece
TRAIN BOTTOM PANEL	6	Piece
TRAIN PLATFORM	1	Piece
TRAIN TOP PANEL	2	Piece
WOODPECKER FIGURE	2	Piece
BENCH FIGURED PANEL	1	Piece
H:100 TUBE PASSING	1	Piece
PLASTIC CLAMP WITH STRAIGHT CONNECTION PART	54	Piece
ANCHORAGE COVER	12	Set
116 x 116 SQUARE PLATFORM	3	Piece
60 x 90 SPIRAL SLIDE PLATFORM	1	Piece
SPIRAL SLIDE RAILING	1	Piece
H:100 STAIRS FROM GROUND TO TOWER	1	Piece
H:100 STAIR RAILS FROM GROUND TO TOWER	1	Set
H:50 STAIRS FROM TOWER TO TOWER	1	Piece
H:50 STAIR RAILS FROM TOWER TO TOWER	1	Set
H:50 INNER STAIRS	1	Piece
Ø27 PANEL INNER PIPE	21	Piece
SCREW HIDING	14	Piece
225 CM TOWER PIPE	2	Piece
250 CM TOWER PIPE	2	Piece
335 CM TOWER PIPE	4	Piece
385 CM TOWER PIPE	4	Piece
TRAIN STAIR	1	Piece

TECHNICAL DRAWING

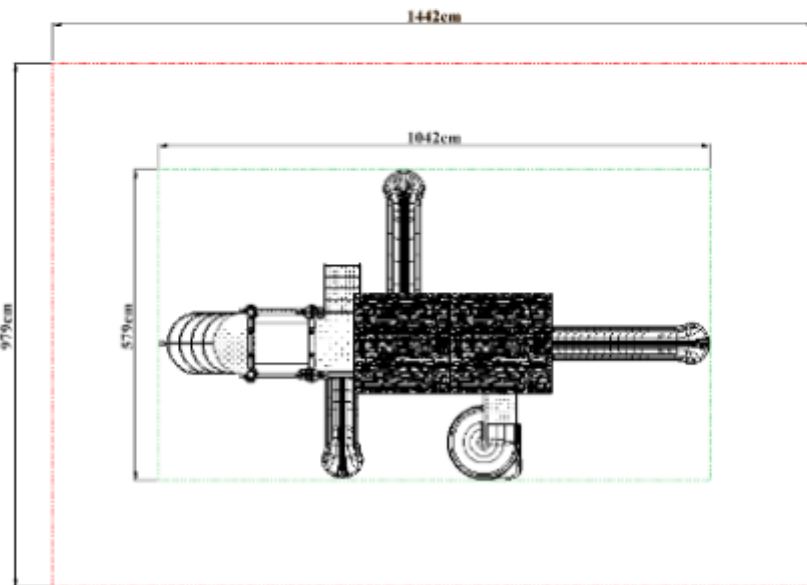
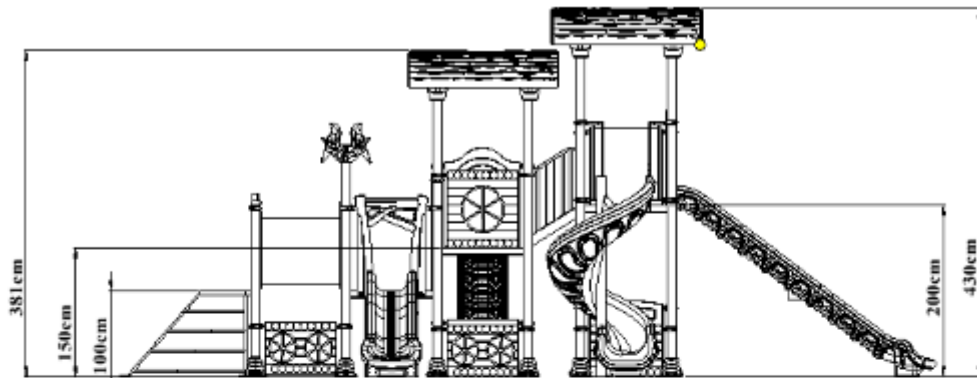

Load-bearing Construction

- Tower, slide, roof, ladder, railing, etc. The main columns that will carry the playgroup elements are manufactured from industrial pipes with a diameter of 114 mm and a wall thickness of min. 2 mm.
- The open top parts of the 114 mm diameter industrial pipes are closed and riveted with self-colored plastic pipe plugs shaped with injection molds in the form of a hemisphere with a wall thickness of 4-6 mm, detailed to prevent corrosion caused by water and moisture.

Polyethylene Products

- The raw material of polyethylene materials to be used in playgrounds is low density linear polyethylene.
- Original raw materials that do not contain any chemicals that may harm children's health and that have EN 1176-1.3 certificate are used.
- In order to prevent electrification, an anti-static agent is added to the polyethylene.
- There is no zinc in the paints used in the polyethylene raw material and the light sensitivity is between 6-8 scales.
- In polyethylene materials, the thickness is at least 5 mm in areas where there is friction and pressure.

Electrostatic Paint

- After all metal parts are manufactured, they are immersed in an iron phosphate bath with 1% concentration at 50 degrees for 15 minutes after rinsing in the dust and degreasing bath with 5% concentration at 70 degrees for 10 minutes.
- Afterward, it is rinsed with clean water again and drying processes are carried out.
- Before the static paint process, sanding is applied in a way to prevent rusting, which may be caused by dust and particles that can settle on the metal parts as a result of air circulation during the drying phase during the resting period.
- After this stage, the material is covered with polyester-based powder paint with a thickness of 60-80 microns, which prevents heating (color fading) in the sun, and then it is heated in an oven at a temperature of at least 200-220 degrees for 10 minutes, and the painting process is completed.

Pipes

- Tower pipes; It is manufactured from SDM pipe with a height of 225cm, 250 cm, 335 cm and 385 cm a diameter of 114 mm, and a wall thickness of min. 2 mm.
- The tower pipes are produced in one piece and perfectly, from horizontal and vertical pipes in length cut according to the determined heights, with a minimum of 2250 mm.
- Pipes with seam marks on the surface are not used in production.
- Adding the length of the pipes, welding, etc. is not extended by the procedure.
- In order to prevent water, moisture, and foreign matter from entering the upper parts of these pipes, colored plastic pipe plugs produced by the injection method are fixed and closed to the pipes with a riveting system.
- The connection points of the pipes with the concrete floor are joined by the sheet metal flange welding method with the size of 20*20*6 mm.
- Connection of the Tower Pipes with the platform the half-moon-shaped ears welded according to the platform size, produced from 6 mm wall thickness, are welded to the pipes and these ears are connected to the platform with the screwing system by means of galvanized bolts and nuts.
- A polyester-based electrostatic powder paint coating process is performed and it is baked in a 200°C oven for 20 minutes.
- Tower pipes are closed with anchor caps produced by injection after assembly.
- 100 cm high, Ø27 elektrostatic paint panel inner pipe is used.



Dimensions	Diameter	Ø 114 mm
	Wall Thickness	Min. 2 mm

116x116 Square Platform

- The platform is manufactured from perforated sheet metal with a minimum size of 116 cm x 116 cm x 8 cm and a minimum wall thickness of 1.5 mm-2 mm.
- Straight designed surface; It is designed to prevent slipping and not allow water retention.
- In the middle of the platform, support sheets are welded to the lower part in order to prevent the sheet from flexing.
- The corners of the platform are manufactured in the form of a quarter circle, enclosing the 114 mm pipe.
- Before the coating process, the sheets are washed with special chemicals, cleared of oil and dirt that will prevent the coating on them, and then coated with the priming method.
- After the priming process, the upper surface of the platform is hot-dip method with an anti-static material mixture with a hardness of -60 ± 5 share A, a density of 1 gr/cm³, minimum kgf/cm² breaking strength, 650-700% breaking elongation, and 100 m³ (max) abrasion. PVC (Plastisol) coating is made.
- PVC thickness is produced at a minimum of 2 mm at each point.
- The platform is attached to the square platform by screwing and its assembly is provided.

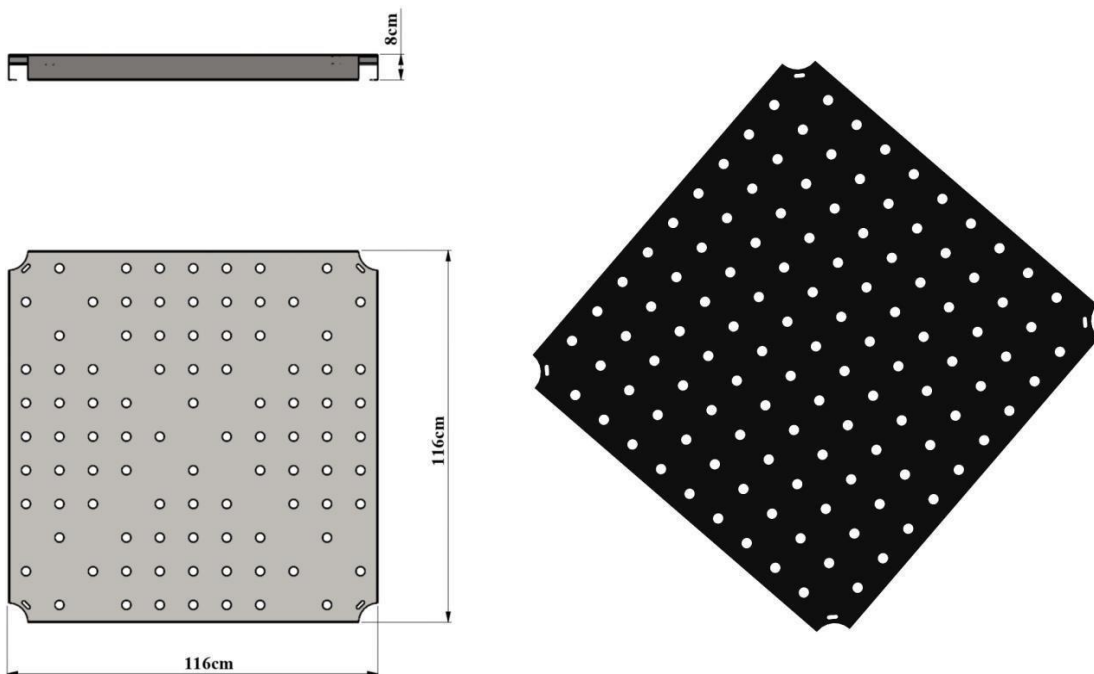

Dimensions	Platform Dimensions	116*116
	Sheet Thickness	2 mm - 8 cm
Features	Plastisol Coated Platform	

60x90 Spiral Extension Platform

- The platform is manufactured from perforated sheet metal with a minimum dimension of 60 cm x 90 cm x 8 cm and a minimum wall thickness of 1.5 mm-2 mm.
- Flat designed surface; It is designed to prevent slipping and not allow water retention.
- In the middle of the platform, support sheets are welded to the lower part in order to prevent the sheet from flexing.
- The corners of the platform are manufactured in the form of a quarter circle, enclosing the 114 mm pipe.
- Before the coating process, the sheets are washed with special chemicals, cleared of oil and dirt that will prevent the coating on them, and then coated with the priming method.
- After the priming process, the upper surface of the platform is hot-dip method with an anti-static material mixture with a hardness of -60 ± 5 share A, a density of 1 gr/cm³, minimum kgf/cm² breaking strength, 650-700% breaking elongation, and 100 m³ (max) abrasion. PVC (Plastisol) coating is made.
- PVC thickness is produced at a minimum of 2 mm at each point.
- The platform is attached to the square platform by screwing and its assembly is provided.

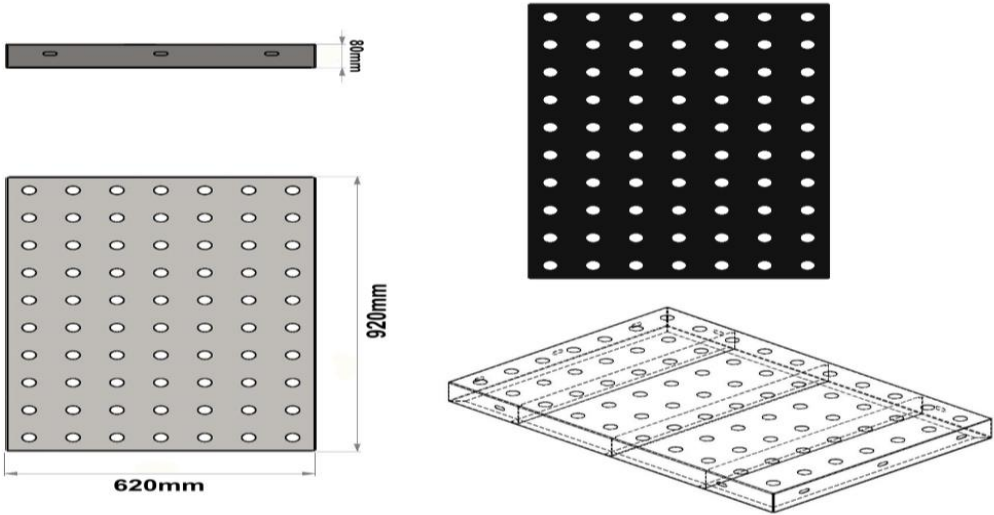

Dimensions	Platform Dimensions	60*90 cm
	Sheet Thickness	2 mm - 8 cm
Features	Plastisol Coated Platform	

Train Platform

- The platform is manufactured from perforated sheet metal with a minimum dimension of 116 cm x 70 cm x 8 cm and a minimum wall thickness of 1.5 mm-2 mm.
- Flat designed surface; It is designed to prevent slipping and not allow water retention.
- In the middle of the platform, support sheets are welded to the lower part in order to prevent the sheet from flexing.
- The corners of the platform are manufactured in the form of a quarter circle, enclosing the 114 mm pipe.
- Before the coating process, the sheets are washed with special chemicals, cleared of oil and dirt that will prevent the coating on them, and then coated with the priming method.
- After the priming process, the upper surface of the platform is hot-dip method with an anti-static material mixture with a hardness of -60 ± 5 share A, a density of 1 gr/cm³, minimum kgf/cm² breaking strength, 650-700% breaking elongation, and 100 m³ (max) abrasion. PVC (Plastisol) coating is made.
- PVC thickness is produced at a minimum of 2 mm at each point.
- The platform is attached to the square platform by screwing and its assembly is provided.

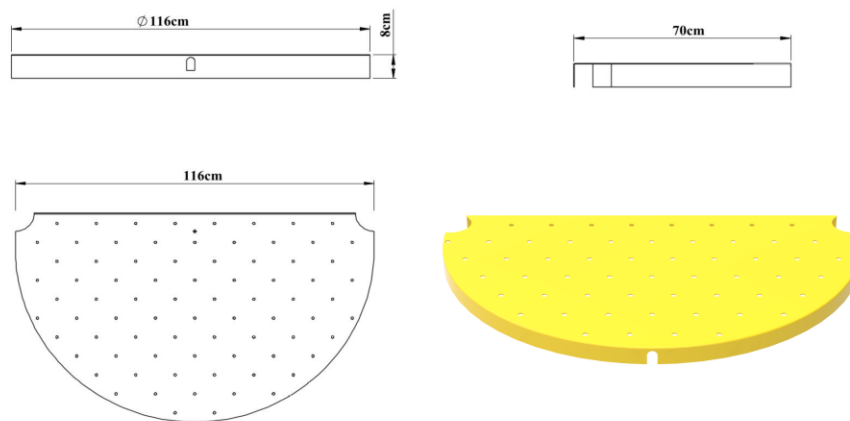

Dimensions	Platform Dimensions	116*70
	Sheet Thickness	2 mm - 8 cm
Features	Plastisol Coated Platform	

Train Stair

- Ladders are manufactured from $\text{Ø } 27$ mm pipe by bending the outer part and welding the pipe that will come to the 7 straight step parts to each other.
- It will be fixed to the $\text{Ø } 114$ mm pipes by screwing to the platform from the ears on the lower part by attaching the vertical mouth and clamp.
- Stairs will be painted with polyester-based electrostatic powder paint after the welding process is completed.

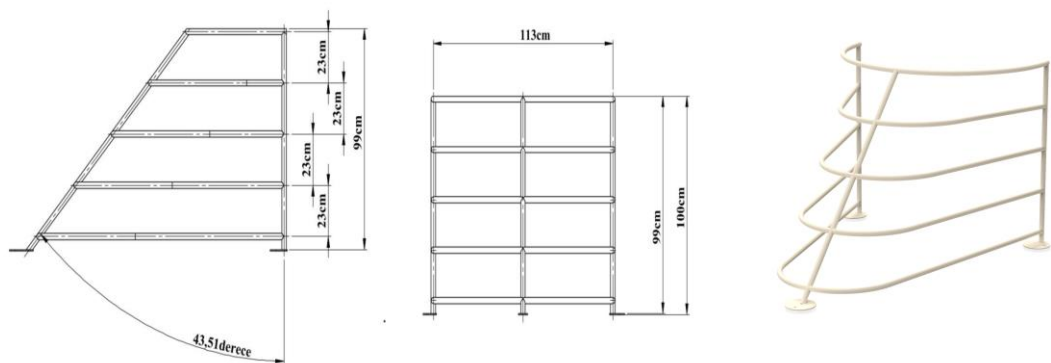

Dimensions	Platform Height	100 cm
Features	Electrostatic paint Stairs + Metal Railing	

Spiral Slide Metal Railing

- The edges of the stair railing are produced from a maximum of 32 mm pipe, and the railings are produced from a minimum of 21 mm pipes.
- Stair railings are painted with polyester-based electrostatic powder paint.
- The slide entrance railing is produced as a single piece of metal.
- The slide entry guardrail is connected to the carrier pole with the help of polyamide clamps with Ø27 mm pipes from the top.
- It is mounted on the platform with the help of galvanized bolts and nuts from the bottom.

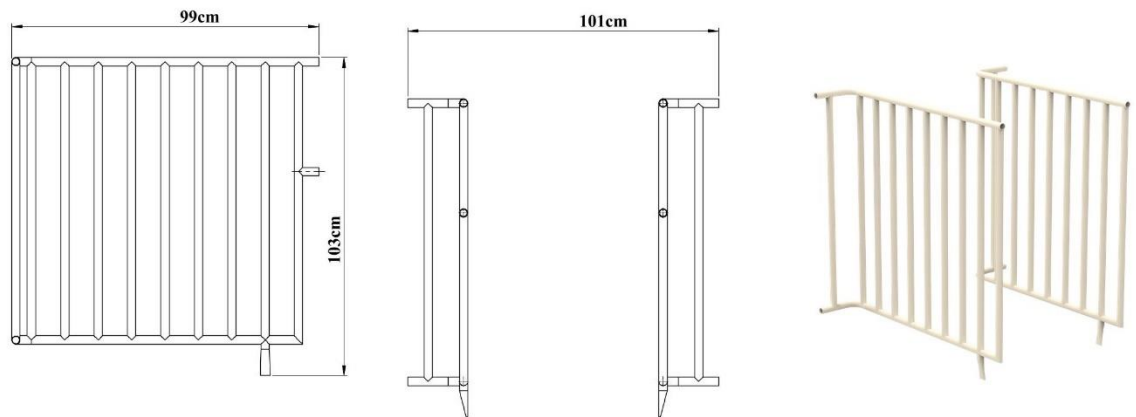

Dimensions	Outer Frame Tube	Ø 32 mm
	Frame Inner Tube	Ø 21 mm
	Minimum Distance Between Railings	88 mm

H:50 Inner Stair

- The ladder is manufactured in such a way that it can reach 50 cm elevation difference from the tower to the platform.
- Ladders are manufactured from $\text{Ø } 27 \text{ mm}$ pipe by bending the outer part and welding the pipe that will come to the 3 straight step parts to each other.
- It will be fixed to the $\text{Ø } 114 \text{ mm}$ pipes by screwing to the platform from the ears on the lower part by attaching the vertical mouth and clamp.
- Stairs will be painted with polyester-based electrostatic powder paint after the welding process is completed.

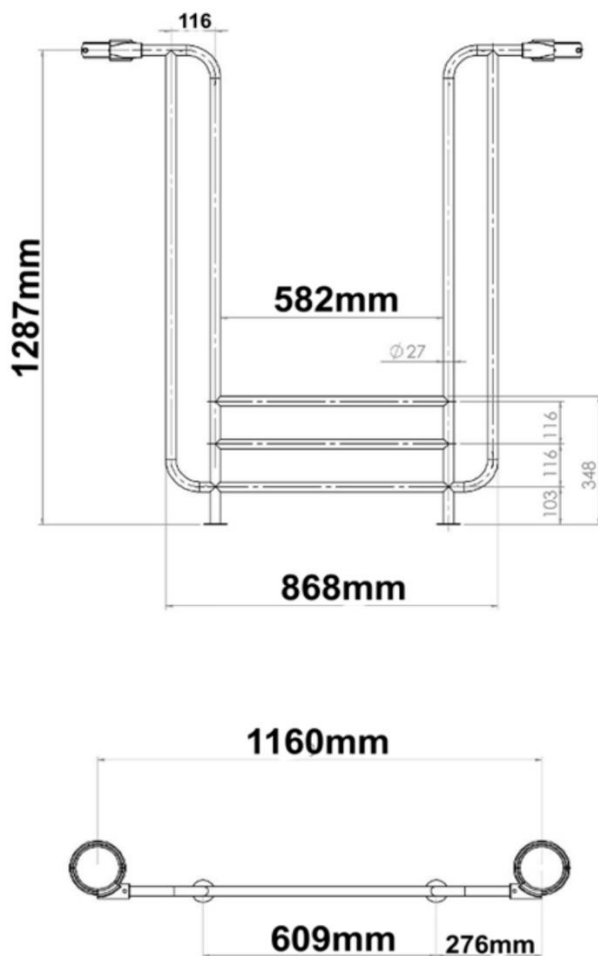

Dimensions	Platform Height	50 cm
Features	Electrostatic paint Stairs + Metal Railing	

H:50 Tower To Tower Stair Rail

- The edges of the stair railing are made of a maximum of $\text{Ø } 27 \text{ mm}$ pipes, and the railings are made of a minimum of $\text{Ø } 21 \text{ mm}$ pipes.
- The distance between the handrails on the stair railing from the platform to the platform is a minimum of 88 mm.
- Stair railings are painted with polyester-based electrostatic powder paint.

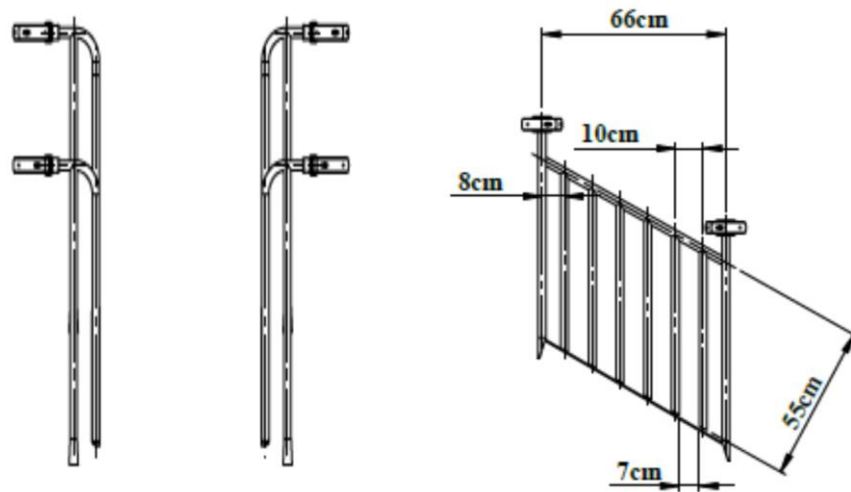

Dimensions	Outer Frame Tube	$\text{Ø } 27 \text{ mm}$
	Frame Inner Tube	$\text{Ø } 21 \text{ mm}$
	Minimum Distance Between Railings	88 mm

H:100 Ground To Tower Stair Rail

- The edges of the stair railing are made of a maximum of $\text{Ø } 32 \text{ mm}$ pipes, and the railings are made of a minimum of $\text{Ø } 21 \text{ mm}$ pipes.
- The distance between the handrails on the stair railing from the platform to the platform is a minimum of 89 mm.
- Stair railings are painted with polyester-based electrostatic powder paint.

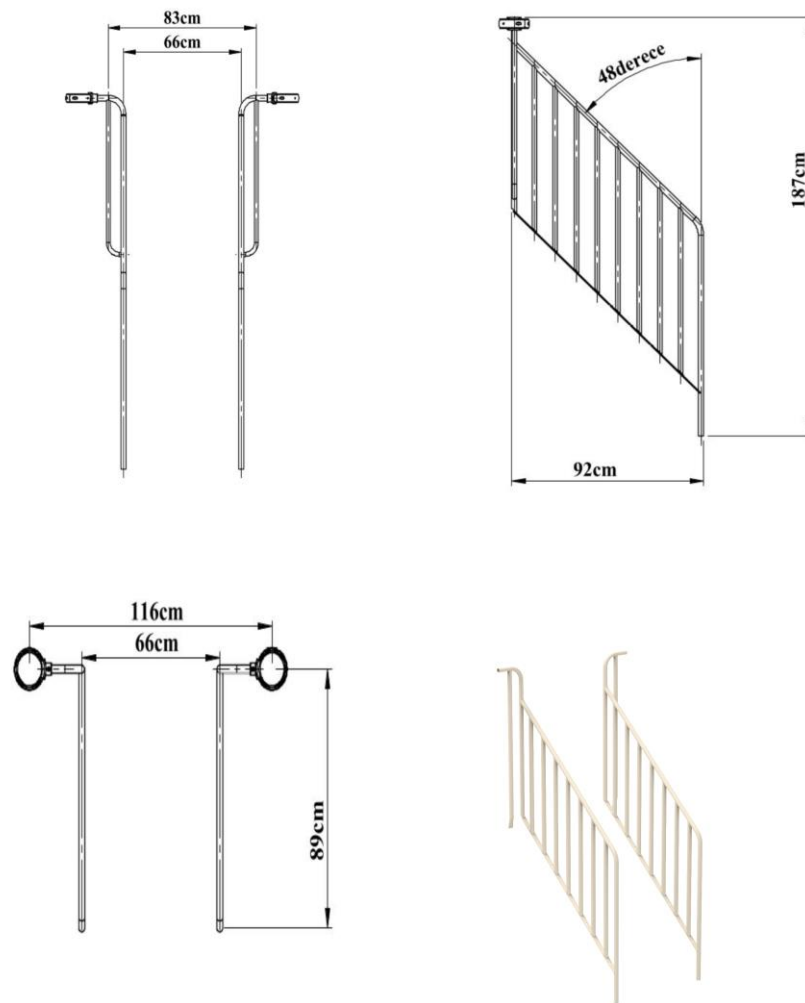

Dimensions	Outer Frame Tube	$\text{Ø } 32 \text{ mm}$
	Frame Inner Tube	$\text{Ø } 21 \text{ mm}$
	Minimum Distance Between Railings	89 mm

H:50 Tower To Tower Ladder

- Ladders are manufactured in one piece with a minimum of 3 steps, with a height difference of 50 cm from the tower to the platform.
- The step height of the stairs is produced with a minimum of 130 mm and a maximum of 200 mm.
- The steps are manufactured from dkp sheet with a minimum wall thickness of 1.5 mm - 2 mm.
- There will be no sharp or sharp edges, corners, or points on the stairs, and no shapes that may cause injury will be used in any way whatsoever.
- Stair treads are mixed -60 ± 5 shore A hardness, 1 gr/cm^3 density, minimum kgf/cm^2 breaking strength, 650-700% breaking elongation and 100 m^3 (max) wear feature, anti-static material mixed with PVC (Plastisol) method by hot dipping method.) will be covered. PVC thickness is at least 2 mm at each point.

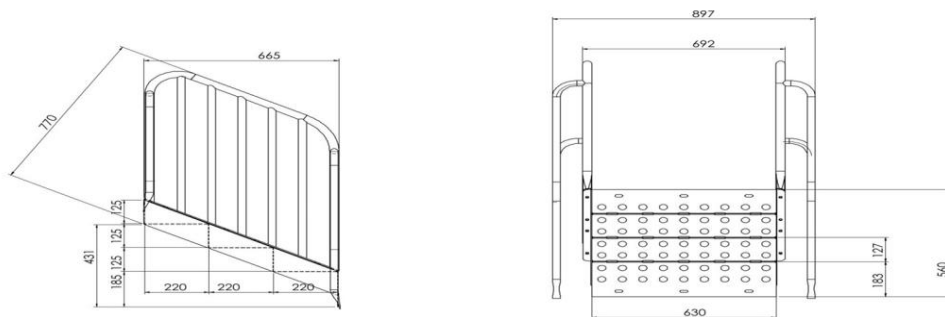

Dimensions	Platform Height	50 cm
	Sheet Thickness	2 mm-1,5 mm
Features	Plastic Coated Stairs + Metal Railing	

H: 100 Cm Ground to Tower Ladder

- Ladders are manufactured in one piece with a minimum of 5 steps, with a height difference of 100 cm from the ground to the platform.
- The step height of the stairs is produced with a minimum of 130 mm and a maximum of 200 mm.
- The steps are manufactured from dkp sheet with a minimum wall thickness of 1.5 mm - 2 mm.
- There will be no sharp or sharp edges, corners, or points on the stairs, and no shapes that may cause injury will be used in any way whatsoever.
- Stair treads are mixed -60 ± 5 share A hardness, 1 gr/cm^3 density, minimum kgf/cm^2 breaking strength, 650-700% breaking elongation and 100 m^3 (max) wear feature, anti-static material mixed with PVC (Plastisol) method by hot dipping method.) will be covered. PVC thickness is at least 2 mm at each point.

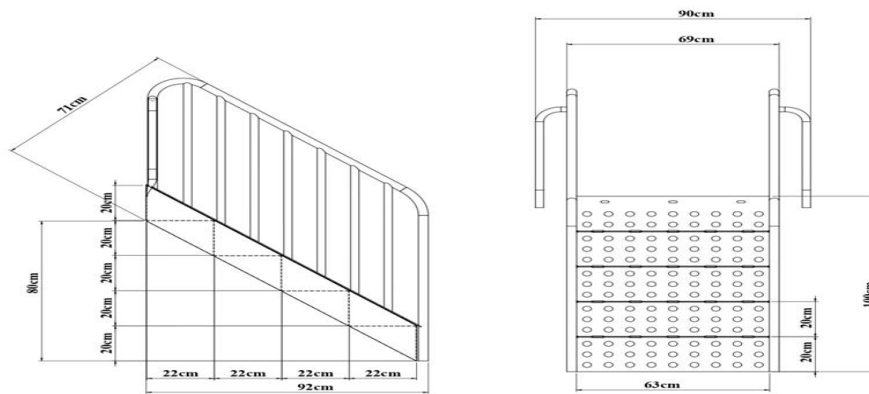

Dimensions	Platform Height	100 cm
	Sheet Thickness	2 mm-1,5 mm
Features	Plastic Coated Stairs + Metal Railing	

Spiral Slide Entrance

- It is manufactured from self-colored polyethylene plastic material as a one-piece and double-walled by rotation molding method with low density (LLDPE Linear Low-Density Polyethylene) designed to prevent falling into the slide entrances.
- In order for the product surface to be smooth; It is produced by sandblasting the surface of the mold made of aluminum or its equivalent material and undergoing a Teflon coating process for surface brightness.

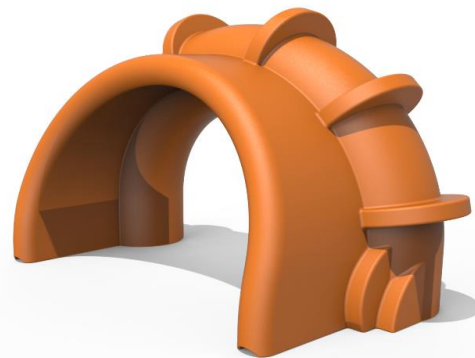
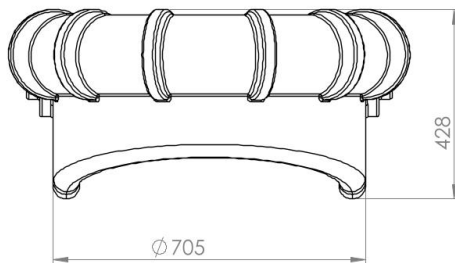
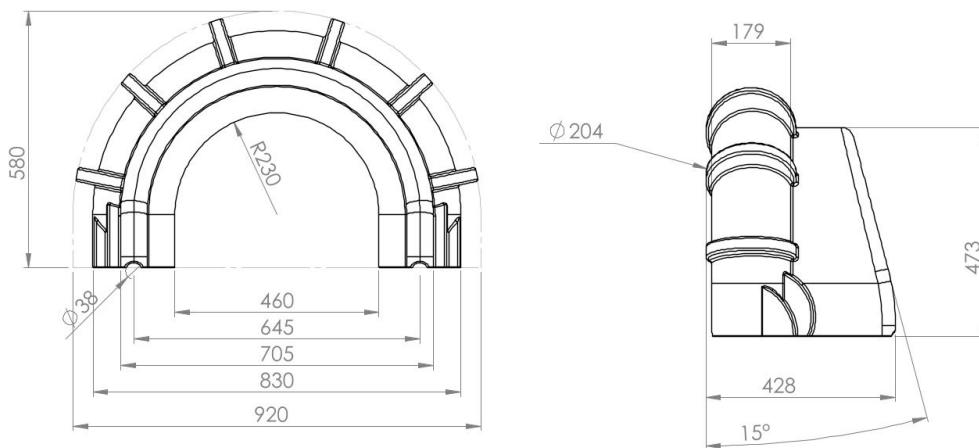

Dimensions	Length	58 cm
	Width	92 cm
	Input Width	46 cm
Features	Min. Weight	8 kg
	Raw material	LLDPE

Wooden Figured Straight Slide Entry

- It is manufactured from self-colored polyethylene plastic material as a one-piece and double-walled by rotation molding method with low density (LLDPE Linear Low-Density Polyethylene) designed to prevent falling into the slide entrances.
- Plastic clamps and vertical mouth connection apparatuses are attached to the $\text{Ø } 27 \text{ mm}$ inner pipe ends attached to the slides, and the $\text{Ø } 114 \text{ mm}$ tower is fixed to the pipes and screwed from the parts of the panels that sit on the platform.
- In order for the product surface to be smooth; It is produced by sandblasting the surface of the mold made of aluminum or its equivalent material and undergoing a Teflon coating process for surface brightness.

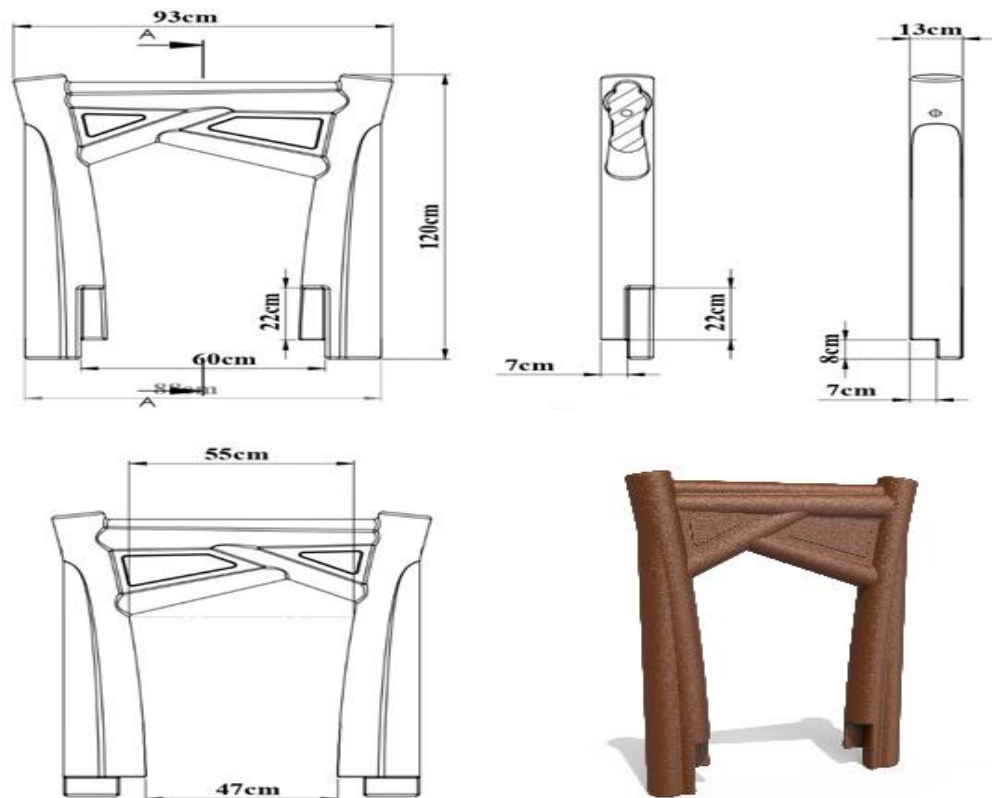

Dimensions	Length	120 cm
	Width	93cm
	Input Width	55 cm
Features	Min. Weight	8,5 kg
	Raw material	LLDPE

Flat Slide Entrance With Hat

- It is manufactured from self-colored polyethylene plastic material as a one-piece and double-walled by rotation molding method with low density (LLDPE Linear Low-Density Polyethylene) designed to prevent falling into the slide entrances.
- Plastic clamps and vertical mouth connection apparatuses are attached to the Ø 27 mm inner pipe ends attached to the slides, and the Ø 114 mm tower is fixed to the pipes and screwed from the parts of the panels that sit on the platform.
- In order for the product surface to be smooth; It is produced by sandblasting the surface of the mold made of aluminum or its equivalent material and undergoing a Teflon coating process for surface brightness.

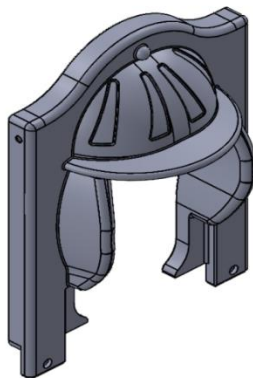
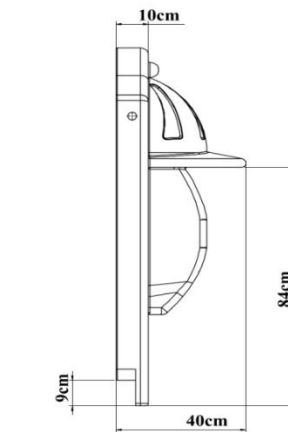
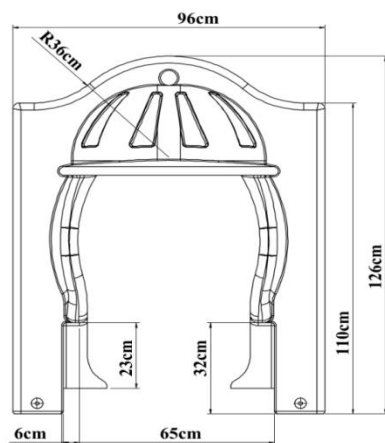

Dimensions	Height	126 cm
	Width	96 cm
	Panel thickness	40 cm
Features	Min Weight	8 kg
	Raw material	LLDPE

Bench Figured Panel

- Bench Figured Panels are manufactured from self-colored polyethylene LLDPE (Linear Low-Density Polyethylene) material as double-walled by rotation molding method.
- Bench Figured Panels are fixed to the main construction with the help of a polyamide-based clamp system with pipes of 81*94 cm dimensions, Ø 27 mm diameter from the top.
- The dyestuffs used in coloring are suitable for child health.

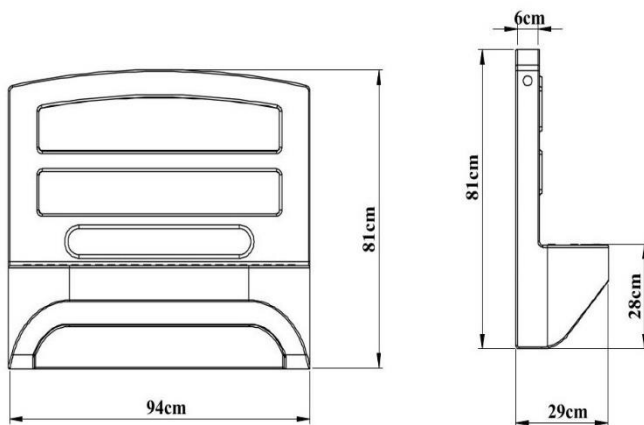

Dimensions	Height	81 cm
	Width	94 cm
Features	Min Weight	9 kg
	Raw material	LLDPE

Train Top Panel

- Train top panels are manufactured from self-colored polyethylene LLDPE (Linear Low-Density Polyethylene) material as double-walled by rotation molding method.
- Train top panels are fixed to the main construction with the help of a polyamide-based clamp system with pipes of 131*90 cm dimensions, Ø 27 mm diameter from the top.
- The dyestuffs used in coloring are suitable for child health.

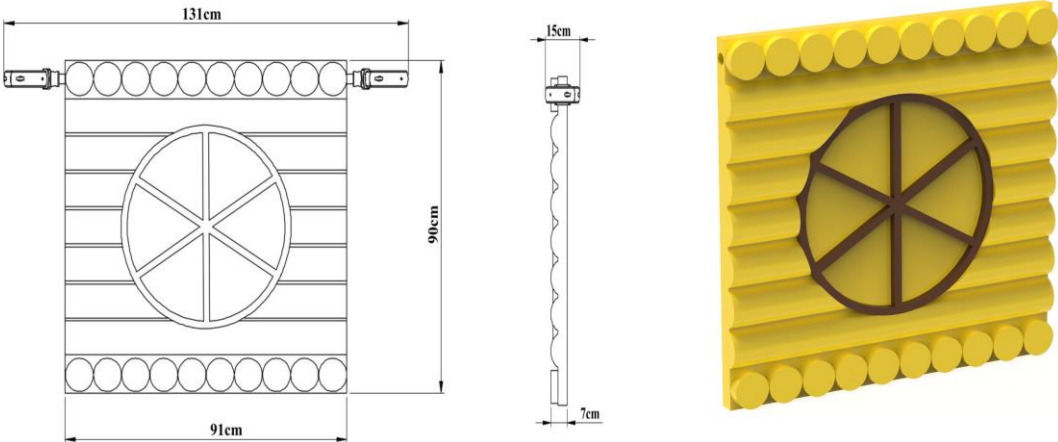

Dimensions	Height	131 cm
	Width	90 cm
	Panel Thickness	7
Features	Min Weight	10 kg
	Raw material	LLDPE

Train Bottom Panel

- Train bottom panels are manufactured from self-colored polyethylene LLDPE (Linear Low-Density Polyethylene) material as double-walled by rotation molding method.
- Train bottom panels are fixed to the main construction with the help of a polyamide-based clamp system with pipes of 139*60 cm dimensions, Ø 27 mm diameter from the top.
- The dyestuffs used in coloring are suitable for child health.

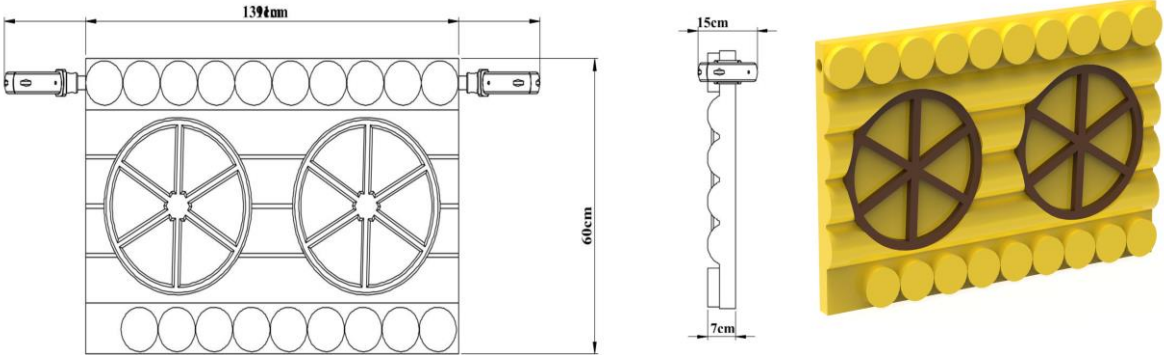

Dimensions	Height	139 cm
	Width	60 cm
	Panel Thickness	7
Features	Min Weight	13 kg
	Raw material	LLDPE

H:100 Straight Slide

- LLDPE (Linear Low-Density Polyethylene) made of self-colored polyethylene plastic material, which is designed to slide from a 100 cm high platform, has a minimum length of 2 meters, is produced in a single piece and double-walled form with a minimum weight of 22 kg.
- It is manufactured in such a way that the inner height dimension of the side protective corners of the slide is 17 cm, the width of the sliding surface is 40 cm, and the slope is 25-30 degrees.
- The slide is fixed to the ground with a metal apparatus from the anchorage point at the bottom of the slide's exit point.
- In order for the product surface to be smooth; Sandblasting is applied to the surface of the mold made of aluminum or its equivalent material, and it is produced by passing the Teflon coating process for surface brightness.
- A flat slide entrance panel is used to ensure safety at the slide entrance.
- LLDPE (Linear Low-Density Polyethylene) from self-colored polyethylene plastic material is produced in one piece by rotation molding method.
- Plastic clamps and vertical mouth connection apparatuses are attached to the $\text{Ø } 27 \text{ mm}$ inner pipe ends attached to the inside of the polyethylene flat slide entrance panels and fixed to the $\text{Ø } 114 \text{ mm}$ tower pipes.

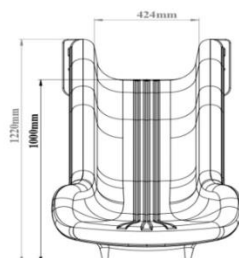
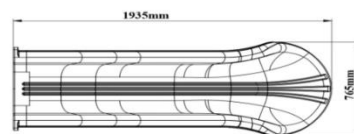

Dimensions	Platform Height	100 cm
	Side Wall Length	17 cm
	Slide Inner Width	40 cm
	Slide Length	210 cm
Features	Raw material	LLDPE
	Min. Slide Weight	22 kg

H: 150 Straight Slide

- LLDPE (Linear Low-Density Polyethylene) made of self-colored polyethylene plastic material, which is designed to slide from a 150 cm high platform, has a minimum length of 3 meters, is produced in a single piece and double-walled form with a minimum weight of 33 kg.
- It is manufactured in such a way that the inner height dimension of the side protective corners of the slide is 17 cm, the width of the sliding surface is 40 cm, and the slope is 25-30 degrees.
- The slide is fixed to the ground with a metal apparatus from the anchorage point at the bottom of the slide's exit point.
- In order for the product surface to be smooth; Sandblasting is applied to the surface of the mold made of aluminum or its equivalent material, and it is produced by passing the Teflon coating process for surface brightness.
- A flat slide entrance panel is used to ensure safety at the slide entrance.
- LLDPE (Linear Low-Density Polyethylene) from self-colored polyethylene plastic material is produced in one piece by rotation molding method.
- Plastic clamps and vertical mouth connection apparatuses are attached to the Ø 27 mm inner pipe ends attached to the inside of the polyethylene flat slide entrance panels and fixed to the Ø 114 mm tower pipes.

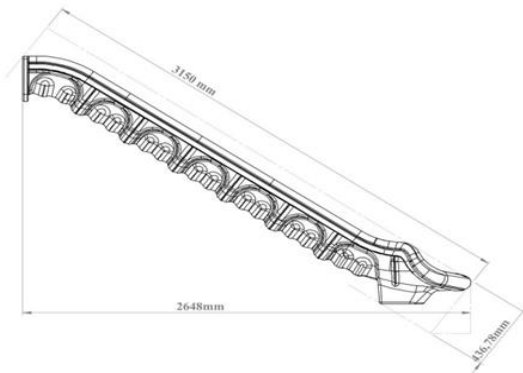
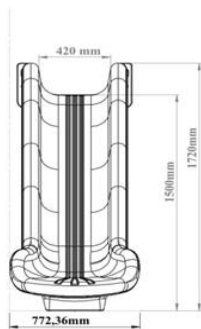

Dimensions	Platform Height	150 cm
	Side Wall Length	17 cm
	Slide Inner Width	40 cm
	Slide Length	315 cm
Features	Raw material	LLDPE
	Min. Slide Weight	33 kg

H: 200 Flat Slide

- LLDPE (Linear Low-Density Polyethylene) made of self-colored polyethylene plastic material, which is designed to slide from a 200 cm high platform, has a minimum length of 4 meters, is produced in a single piece and double-walled form with a minimum weight of 42 kg.
- It is manufactured in such a way that the inner height dimension of the side protective corners of the slide is 17 cm, the width of the sliding surface is 40 cm, and the slope is 25-30 degrees.
- The slide is fixed to the ground with a metal apparatus from the anchorage point at the bottom of the slide's exit point.
- In order for the product surface to be smooth; Sandblasting is applied to the surface of the mold made of aluminum or its equivalent material, and it is produced by passing the Teflon coating process for surface brightness.
- A flat slide entrance panel is used to ensure safety at the slide entrance.
- LLDPE (Linear Low-Density Polyethylene) from self-colored polyethylene plastic material is produced in one piece by rotation molding method.
- Plastic clamps and vertical mouth connection apparatuses are attached to the Ø 27 mm inner pipe ends attached to the inside of the polyethylene flat slide entrance panels and fixed to the Ø 114 mm tower pipes.

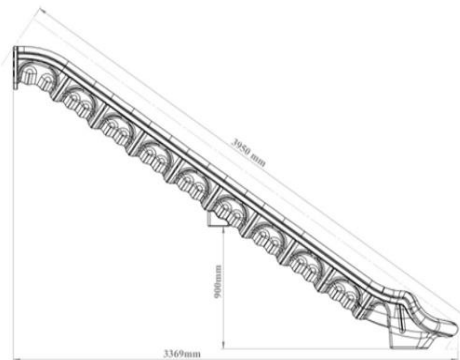
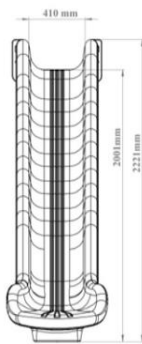

Dimensions	Platform Height	200 cm
	Side Wall Length	17 cm
	Slide Inner Width	40 cm
	Slide Length	380 cm
Features	Raw material	LLDPE
	Min. Slide Weight	42 kg

H:200 Spiral Slide

- It is produced from a single piece of polyethylene plastic material with a low-density LLDPE (Linear Low-Density Polyethylene) rotation molding method, which is spirally molded from a 200±10 cm high platform to a minimum Ø114 mm profile pipe in its center, in a self-colored form.
- It is manufactured in such a way that the inside height measure of the side protective corners of the slide is 17 cm, the width of the sliding surface is 40 cm, and the slope is 25-30 degrees.
- In order to ensure safety, metal spiral guardrails are used on both sides of the slide entrance, and a polyethylene entrance barrier with a minimum weight of 8 kg is used on the upper part.
- A 20*20*5 mm diameter flange is welded to the middle part of the slide, and it is fixed to the floor with an SDM pipe with a diameter of Ø 114 mm, a length of 230 cm.

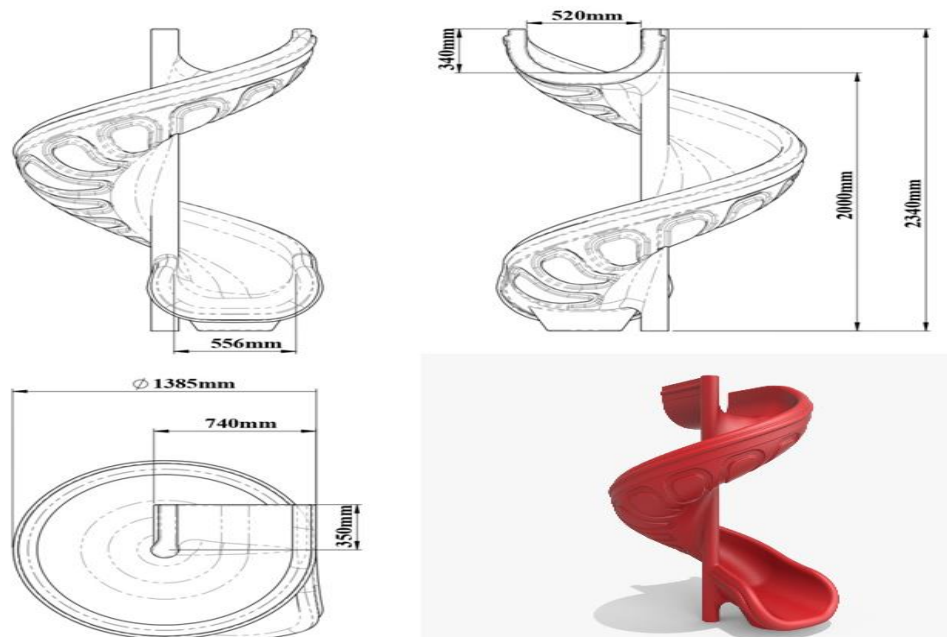

Dimensions	Platform Height	200 cm
	Side Wall Length	17 cm
	Slide Inner Width	40 cm
	Slide Length	234cm
Features	Raw material	LLDPE
	min. Slide Weight	50 kg

100 Cm Tube Passage

- H:100 tube passage with a minimum length of 1 m, designed to allow passage between two platforms; It is manufactured from 3 parts, 2 pcs tube inlets and 1 pcs 110 degree tube, and from self-colored polyethylene plastic material, LLDPE (Linear Low Density Polyethylene) rotation molding method.
- Plastic clamps and vertical mouth connection apparatuses are attached to the ends of $\text{Ø } 27$ inner pipes attached to the tube passages, and 114 towers are fixed to the pipes and screwed from the parts of the panels that sit on the platform.
- The product produced as disassembled; It is made a whole by assembling the given tube parts to each other according to the given angles.
- In order for the product surface to be smooth; Sandblasting is applied to the surface of the mold made of aluminum or its equivalent material, and it is produced by passing the Teflon coating process for surface brightness.

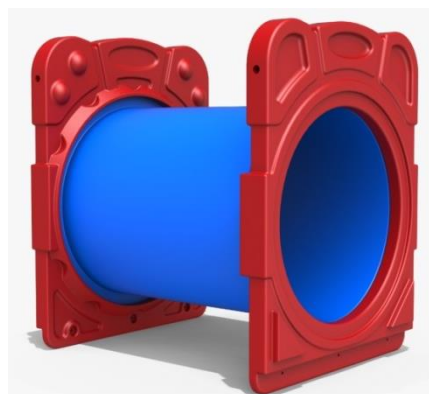
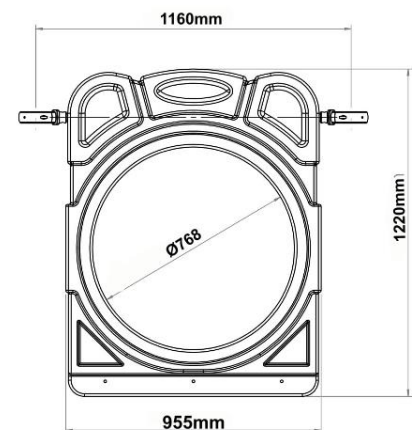
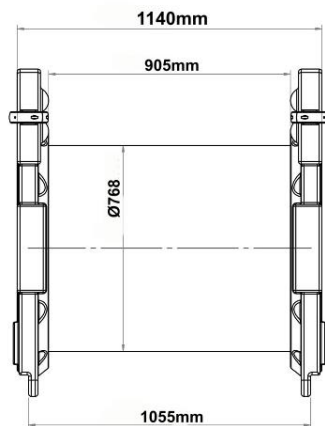

Dimensions	Tube Passage Length	124 cm
	Panel Entry Diameter	75 cm
Features	Min. Weight	42 kg
	Raw material	LLDPE

Train Roof

- The roof of the Train is manufactured from polyethylene plastic material (LLDPE Linear Low Density Polyethylene) with a minimum height of 57 cm by rotation molding method, in 1 pieces with self-color.
- In accordance with TS EN 1176-1, when measuring on the platform, the height between the platform and the roof is at least 1800 mm.
- The Train roof must be directly connected to the main construction.
- No connecting element is used in between.

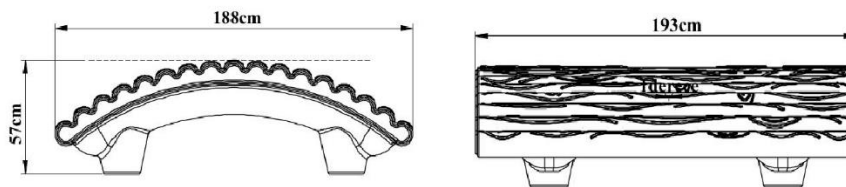

Dimensions	Length	193 cm
	Width	188 cm
	min. Train Roof Height	57 cm
Features	min. Train Roof Weight	42 kg
	Raw materials	LLDPE

Woodpecker Figure

- The woodpecker figure is used to add visuality to playgroups.
- It is produced from polyethylene material suitable for indoor and outdoor use in accordance with 114 mm pipe.
- It is resistant to UV lights and is designed not to harm the user.
- The woodpecker figure weighs 2 kg.



Ø 114 Hat Plug

- The cap plug is used to close open-ended pipes in children's playgroups, seesaws, swings, and other products.
- The cap plug is manufactured from polyethylene material for indoor and outdoor use.
- The product is resistant to UV lights.
- Its design is oval in a way that does not harm the user.
- It grasps the pipe with its 114 mm double-walled inlet and is easy to install.

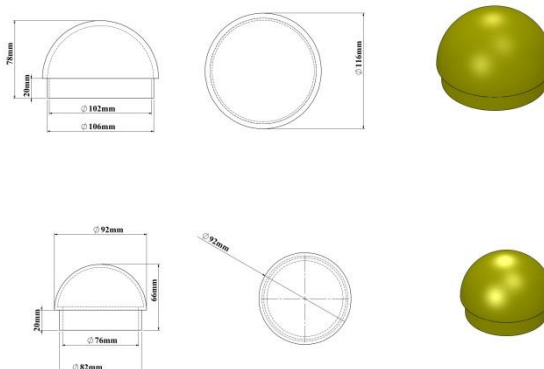

Ø 114 Anchor Cover

- Anchor caps measuring 114 mm are used to cover open-ended pipes in children's playgrounds, seesaws, swings, and other products.
- Anchor caps are produced from polythene plastic material for indoor and outdoor use.
- It is resistant to UV lights and is designed not to harm the user.
- It is manufactured as double-walled and assembled with a screwing system.

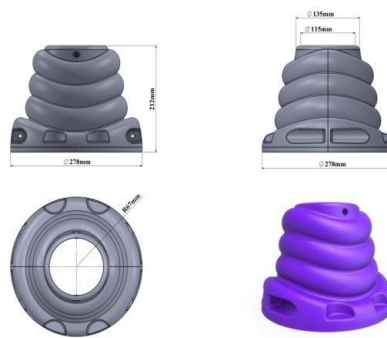

Screw Concealment

- Screw hides are used in all playgroups to prevent possible accidents and injuries.
- Screw hides; It provides an aesthetic appearance to playgrounds and parking elements by allowing mounting elements such as screws and nuts to be hidden.
- Screw closures are produced from polythene plastic material by injection method, suitable for indoor and outdoor use.
- It is resistant to UV lights and is designed not to harm the user.

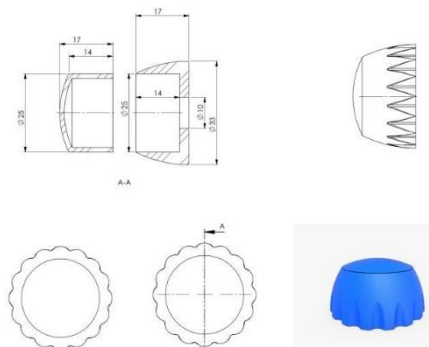

Connectors

Ø 114 Plastic Clamps

- Plastic clamps, board on the playgroup, slide entrance, railings, etc. It enables the elements to be mounted on the carrier system with a diameter of 114 mm.
- Clamps are manufactured from fibrous polyamide raw material by injection method.
- The clamp is designed in accordance with the inner diameter 114 mm pipe.
- It does not rotate on the pipe surface when tightened.
- After the clamp is connected, there are no protrusions or sharp corners that may cause injury in any part of the clamp.
- It can be produced in the desired color.

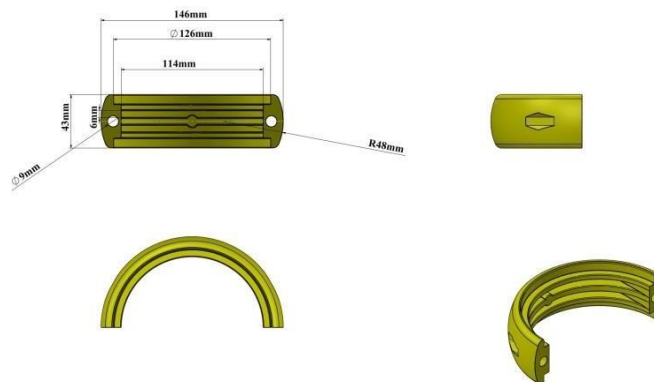

Ø114 Perpendicular Mouth

- Upright mouth, curved mouth, and platform wedge apparatus are used in the assembly of various playgrounds and sports equipment.
- It is produced from polyethylene material suitable for 114 mm pipe, suitable for indoor and outdoor use.
- The product is resistant to UV lights.
- Its design is in a structure that will not harm the user.
- It can be produced in desired colors.

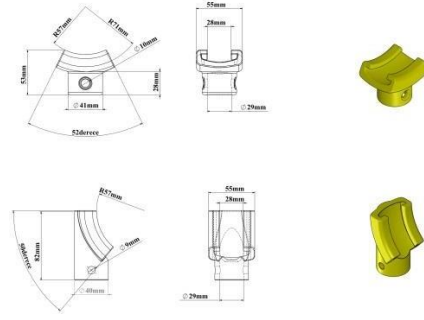

Bolts, Nuts and Washers

- The fasteners (bolts, washers, and nuts) used in-game systems are produced as GeometB321 Plus or galvanized coating to protect them against corrosion.
- There are no nut and bolt protrusions anywhere in the playset.
- Except for the camber head nut within the playgroup, all nuts are produced with fiber.

