



PT-15



Age range
3+



Number of Users
7



Free Fall Height
1m



Height
4,26cm



Assemble Area
30m²



Sitting Area
4,46cm*6,55cm



Safety Area
6,96cm*9,05cm

PRODUCT TREE

CHONICAL ROOF	1	Piece
H:100 STRAIGHT SLIDE	1	Piece
H:100 DOUBLE SLIDE	1	Piece
HAT FIGURED SLIDE ENTRY	1	Piece
BUGS BUNNY SLIDE ENTRY	1	Piece
DUCK FIGURED PANEL	1	Piece
H:100 CATERPILLAR STAIRS	1	Piece
116 x 116 SQUARE PLATFORM	1	Piece
ANCHORAGE COVER	6	Set
SCREW HIDING	12	Piece
PLASTIC CLAMP WITH STRAIGHT CONNECTION PART	12	Piece
285 CM TOWER PIPE	4	Piece
Ø27 PANEL INNER PIPE	4	Piece
ATTACHED CLASSICAL SWING	1	Set

TECHNICAL DRAWING

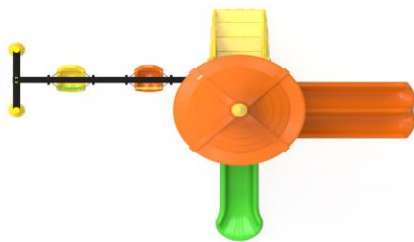
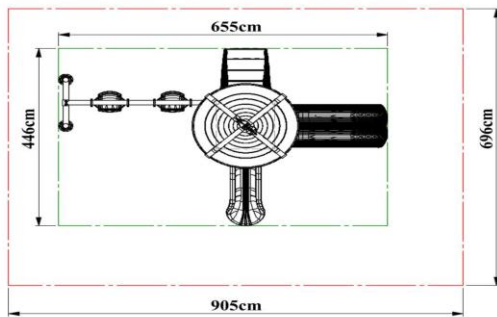
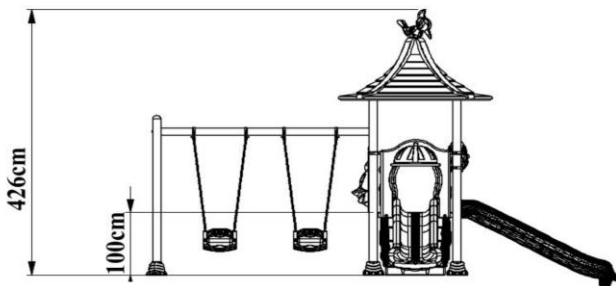

Load-bearing Construction

- Tower, slide, roof, ladder, railing, etc. The main columns that will carry the playgroup elements are manufactured from industrial pipes with a diameter of 114 mm and a wall thickness of min. 2 mm.
- The open top parts of the 114 mm diameter industrial pipes are closed and riveted with self-colored plastic pipe plugs shaped with injection molds in the form of a hemisphere with a wall thickness of 4-6 mm, detailed to prevent corrosion caused by water and moisture.

Polyethylene Products

- The raw material of polyethylene materials to be used in playgrounds is low density linear polyethylene.
- Original raw materials that do not contain any chemicals that may harm children's health and that have EN 1176-1.3 certificate are used.
- In order to prevent electrification, an anti-static agent is added to the polyethylene.
- There is no zinc in the paints used in the polyethylene raw material and the light sensitivity is between 6-8 scales.
- In polyethylene materials, the thickness is at least 5 mm in areas where there is friction and pressure.

Electrostatic Paint

- After all metal parts are manufactured, they are immersed in an iron phosphate bath with 1% concentration at 50 degrees for 15 minutes after rinsing in the dust and degreasing bath with 5% concentration at 70 degrees for 10 minutes.
- Afterward, it is rinsed with clean water again and drying processes are carried out.
- Before the static paint process, sanding is applied in a way to prevent rusting, which may be caused by dust and particles that can settle on the metal parts as a result of air circulation during the drying phase during the resting period.
- After this stage, the material is covered with polyester-based powder paint with a thickness of 60-80 microns, which prevents heating (color fading) in the sun, and then it is heated in an oven at a temperature of at least 200-220 degrees for 10 minutes, and the painting process is completed.

Pipes

- Tower pipes; It is manufactured from SDM pipe with a height of 285 cm a diameter of 114 mm, and a wall thickness of min. 2 mm.
- The tower pipes are produced in one piece and perfectly, from horizontal and vertical pipes in length cut according to the determined heights, with a minimum of 2250 mm.
- Pipes with seam marks on the surface are not used in production.
- Adding the length of the pipes, welding, etc. is not extended by the procedure.
- In order to prevent water, moisture, and foreign matter from entering the upper parts of these pipes, colored plastic pipe plugs produced by the injection method are fixed and closed to the pipes with a riveting system.
- The connection points of the pipes with the concrete floor are joined by the sheet metal flange welding method with the size of 20*20*6 mm.
- Connection of the Tower Pipes with the platform the half-moon-shaped ears welded according to the platform size, produced from 6 mm wall thickness, are welded to the pipes and these ears are connected to the platform with the screwing system by means of galvanized bolts and nuts.
- A polyester-based electrostatic powder paint coating process is performed and it is baked in a 200°C oven for 20 minutes.
- Tower pipes are closed with anchor caps produced by injection after assembly.
- 100 cm high, Ø27 elektrostatic paint panel inner pipe is used.



Dimensions	Diameter	Ø 114 mm
	Wall Thickness	Min. 2 mm

116x116 Square Platform

- The platform is manufactured from perforated sheet metal with a minimum size of 116 cm x 116 cm x 8 cm and a minimum wall thickness of 1.5 mm-2 mm.
- Flat designed surface; It is designed to prevent slipping and not allow water retention.
- In the middle of the platform, support sheets are welded to the lower part in order to prevent the sheet from flexing.
- The corners of the platform are manufactured in the form of a quarter circle, enclosing the 114 mm pipe.
- Before the coating process, the sheets are washed with special chemicals, cleared of oil and dirt that will prevent the coating on them, and then coated with the priming method.
- After the priming process, the upper surface of the platform is hot-dip method with an anti-static material mixture with a hardness of -60 ± 5 share A, a density of 1 gr/cm^3 , minimum kgf/cm^2 breaking strength, 650-700% breaking elongation, and 100 m^3 (max) abrasion. PVC (Plastisol) coating is made.
- PVC thickness is produced at a minimum of 2 mm at each point.

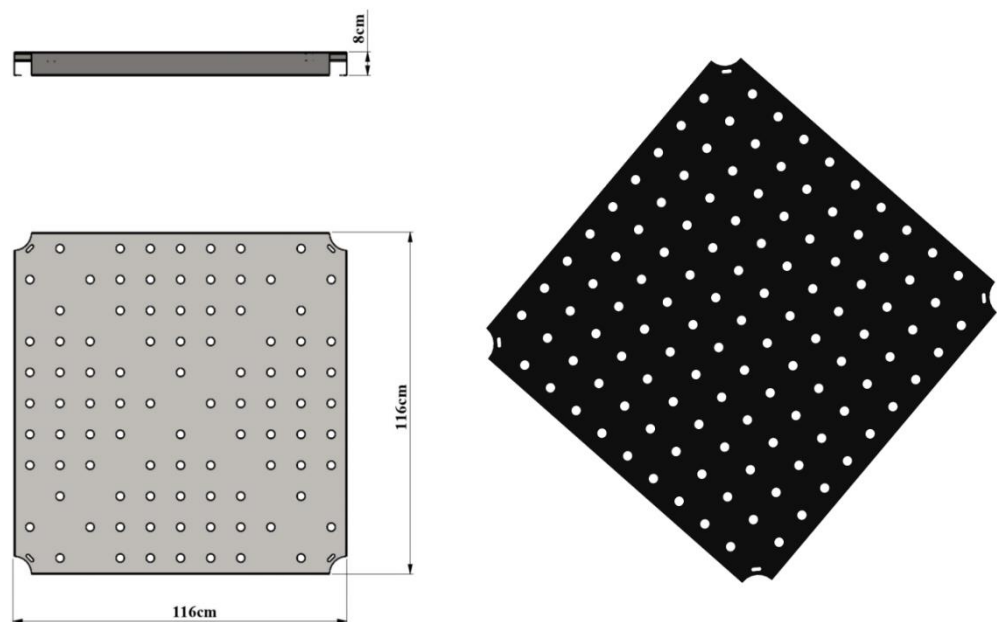

Dimensions	Platform Dimensions	116*116 cm
	Sheet Thickness	2 mm - 8 cm
Features	Plastisol Coated Platform	

H:100 Plastic Stair

- The stair is manufactured from self-colored polyethylene plastic material, LLDPE (Linear Low Density Polyethylene) rotation molding method, with a minimum of 4 steps, in a way that can reach 100 cm level difference from the ground to the platform.
- There are patterns designed for children on the stair railing.
- Stair railing is manufactured from self-colored polyethylene plastic material LLDPE (Linear Low Density Polyethylene) by rotation molding method.
- In order for the product surface to be smooth; Sandblasting is applied to the surface of the mold made of aluminum or equivalent material and it is produced by passing the Teflon coating process for surface brightness.

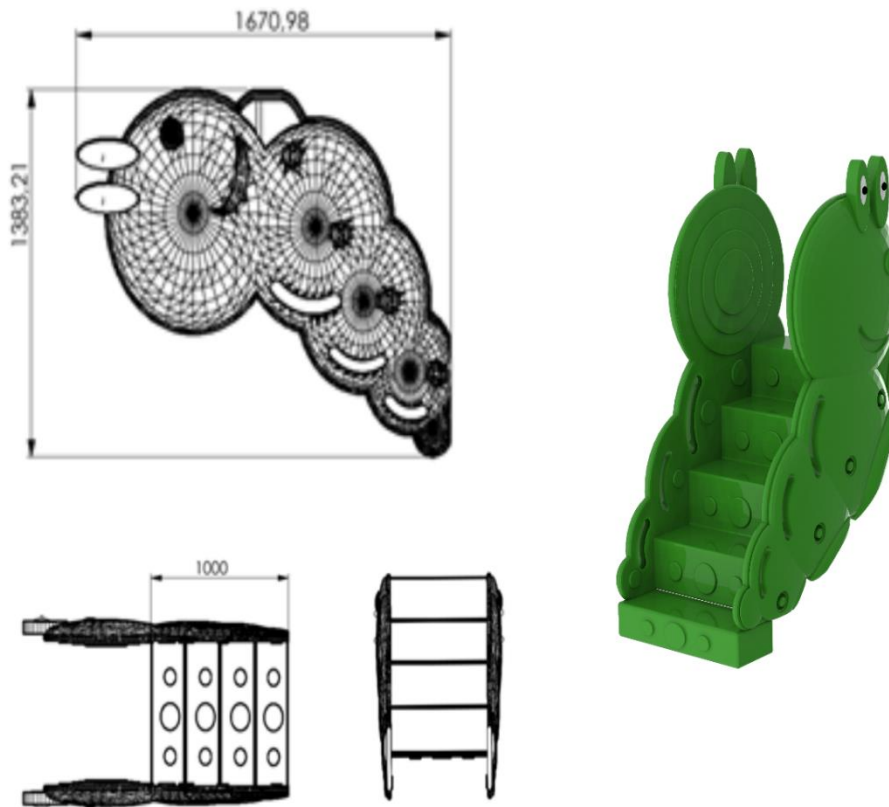

Dimensions	Platform Height	100 cm
	Railing Height	167 cm
	Railing Width	138 cm
Features	min. Weight	50 kg
	Raw materials	LLDPE

Flat Slide Entrance With Hat

- It is manufactured from self-colored polyethylene plastic material as a one-piece and double-walled by rotation molding method with low density (LLDPE Linear Low-Density Polyethylene) designed to prevent falling into the slide entrances.
- Plastic clamps and vertical mouth connection apparatuses are attached to the Ø 27 mm inner pipe ends attached to the slides, and the Ø 114 mm tower is fixed to the pipes and screwed from the parts of the panels that sit on the platform.
- In order for the product surface to be smooth; It is produced by sandblasting the surface of the mold made of aluminum or its equivalent material and undergoing a Teflon coating process for surface brightness.

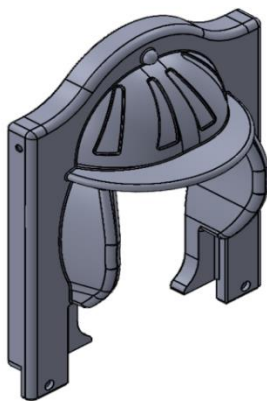
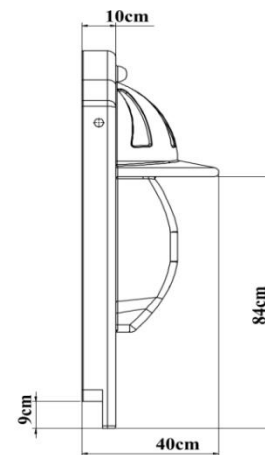
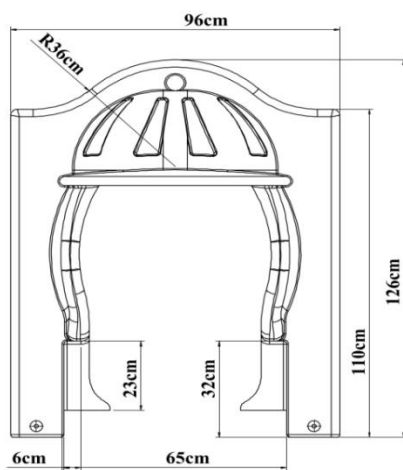

Dimensions	Height	126 cm
	Width	96 cm
	Panel thickness	40 cm
Features	Min Weight	8 kg
	Raw material	LLDPE

Duck Figured Panel

- Duck figured panels are manufactured from self-colored polyethylene LLDPE (Linear Low-Density Polyethylene) material as double-walled by rotation molding method.
- The Duck figured panels are fixed to the main construction with the help of a polyamide-based clamp system with pipes of 95x122 cm dimensions Ø, 27 mm diameter from the top.
- The dyestuffs used in coloring are suitable for child health.

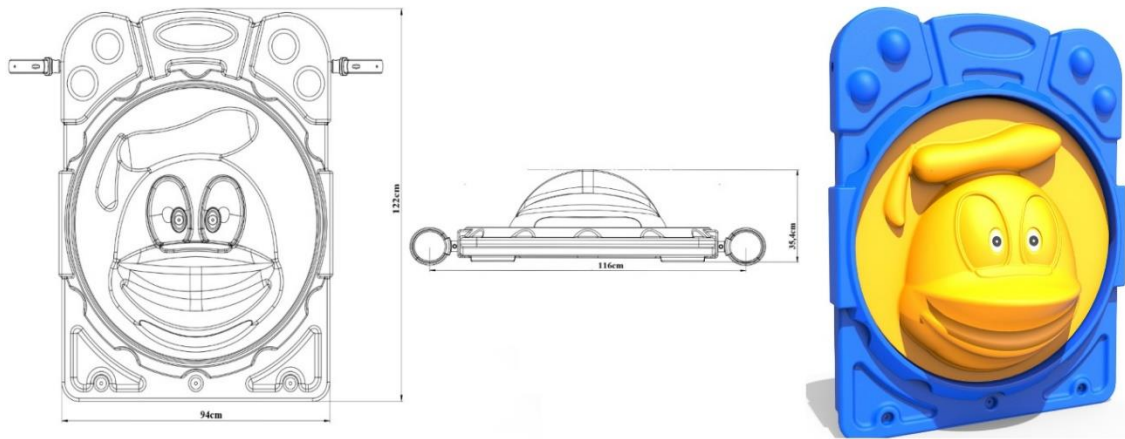

Dimensions	Height	122 cm
	Width	95 cm
	Panel thickness	35,4 cm
Features	Min Weight	12,5 kg
	Raw material	LLDPE

Bugs Bunny Slide Entry

- Bugs Bunny Slide Entry are manufactured from self-colored polyethylene LLDPE (Linear Low-Density Polyethylene) material as double-walled by rotation molding method.
- Bugs Bunny Slide Entry are fixed to the main construction with the help of a polyamide-based clamp system with galvanized pipes of 67*93 cm dimensions, Ø 27 mm diameter from the top, and 2 mm wall thickness.
- The dyestuffs used in coloring are suitable for child health.

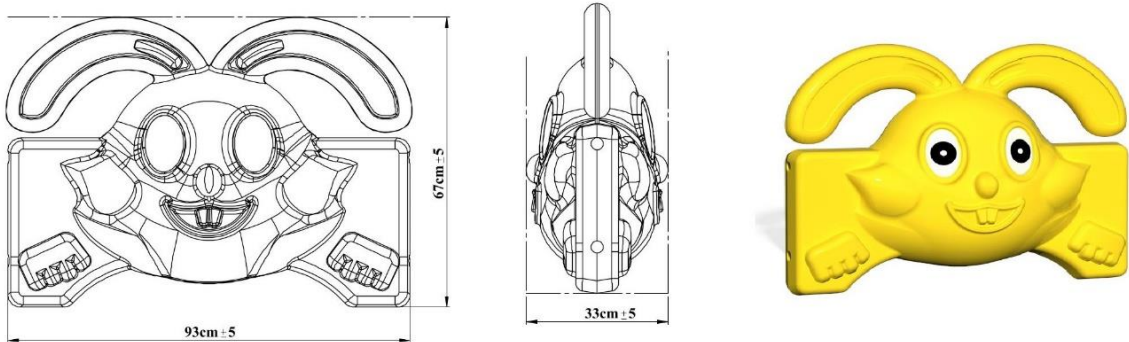

Dimensions	Height	67 cm
	Width	93 cm
	Panel thickness	33 cm
Features	Min Weight	4,5 kg
	Raw material	LLDPE

H:100 Straight Slide

- LLDPE (Linear Low-Density Polyethylene) made of self-colored polyethylene plastic material, which is designed to slide from a 100 cm high platform, has a minimum length of 2 meters, is produced in a single piece and double-walled form with a minimum weight of 22 kg.
- It is manufactured in such a way that the inner height dimension of the side protective corners of the slide is 17 cm, the width of the sliding surface is 40 cm, and the slope is 25-30 degrees.
- The slide is fixed to the ground with a metal apparatus from the anchorage point at the bottom of the slide's exit point.
- In order for the product surface to be smooth; Sandblasting is applied to the surface of the mold made of aluminum or its equivalent material, and it is produced by passing the Teflon coating process for surface brightness.
- A flat slide entrance panel is used to ensure safety at the slide entrance.
- LLDPE (Linear Low-Density Polyethylene) from self-colored polyethylene plastic material is produced in one piece by rotation molding method.
- Plastic clamps and vertical mouth connection apparatuses are attached to the Ø 27 mm inner pipe ends attached to the inside of the polyethylene flat slide entrance panels and fixed to the Ø 114 mm tower pipes.

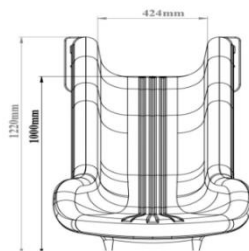
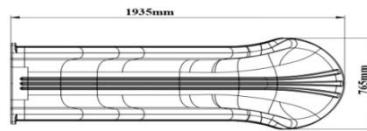

Dimensions	Platform Height	100 cm
	Side Wall Length	17 cm
	Slide Inner Width	40 cm
	Slide Length	210 cm
Features	Raw material	LLDPE
	Min. Slide Weight	22 kg

H:100 Double Slide

- LLDPE (Linear Low-Density Polyethylene) made of self-colored polyethylene plastic material, which is designed to slide from a 100 cm high platform is produced in a single piece and double-walled form with a minimum weight of 40 kg.
- It is manufactured in such a way that the inner height dimension of the side protective corners of the slide is 25 cm, the width of the sliding surface is 42 cm, and the slope is 25-30 degrees.
- A flat slide entrance panel is used to ensure safety at the slide entrance.
- In order for the product surface to be smooth; Sandblasting is applied to the surface of the mold made of aluminum or its equivalent material, and it is produced by passing the Teflon coating process for surface brightness.
- The slide is fixed to the ground with a metal apparatus from the anchorage point at the bottom of the slide's exit point.

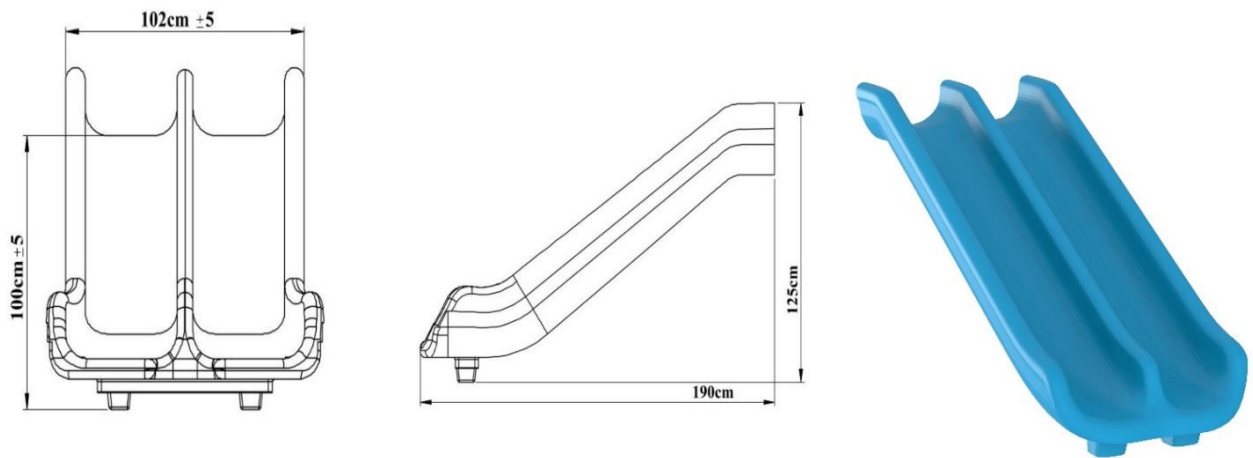

Dimensions	Platform Height	100 cm
	Side Wall Length	25cm
	Slide Inner Width	42 cm
	Slide Length	190 cm
Features	Raw material	LLDPE
	Min. Slide Weight	40 kg

Conical Roof

- The conical is manufactured from polyethylene plastic material, LLDPE (Linear Low-Density Polyethylene) with a minimum height of 94 cm, by rotation molding method, in two parts as body and upper apparatus, in self-color.
- In accordance with TS EN 1176-1, when measuring on the platform, the height between the platform and the roof is at least 1800 mm.
- The conical roof is manufactured to be directly connected to the main construction.
- No connecting element is used in between.
- The apparatus in its four corners are mounted with screws.
- Its upper apparatus is mounted on the roof body with an imbus screw system.

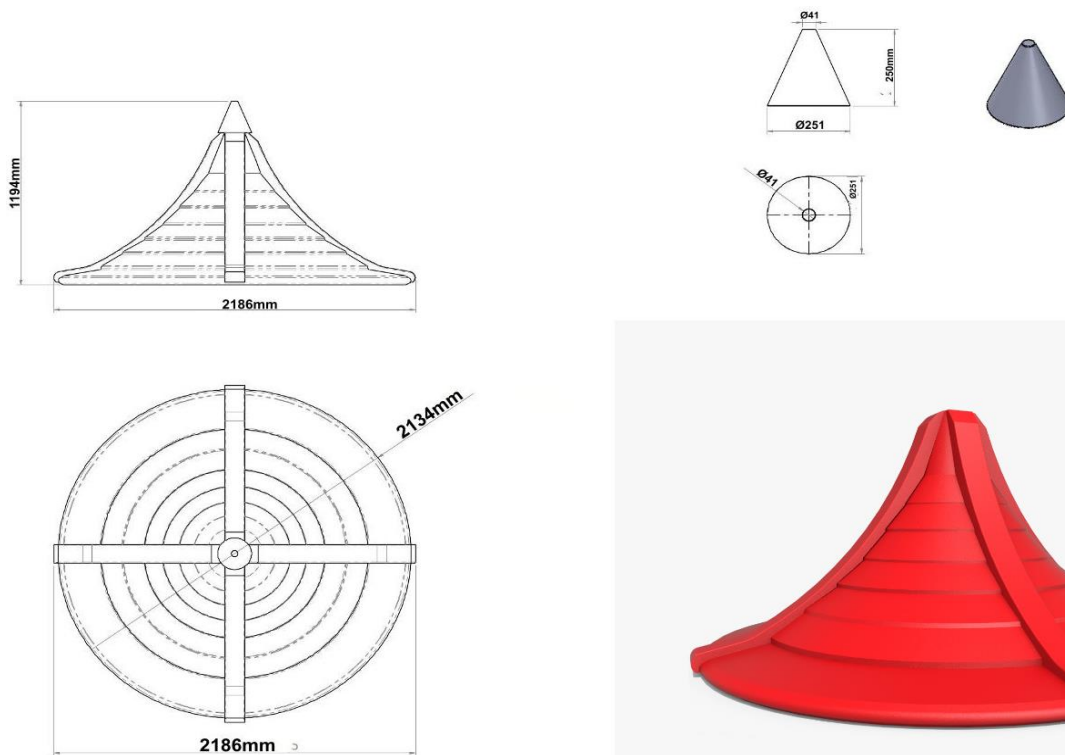

Dimensions	Diameter	185 cm
	Min. Conical Roof Height	94 cm
Features	Min. Conical Roof Weight	30 kg
	Raw material	LLDPE

Attached Classical Swing

- The cutting points of the horizontal and vertical pipes from the SDM pipe with a diameter of 114 mm are connected to each other with doetail metal clamps with a minimum wall thickness of 3 to form a right angle.
- The open parts of the Ø 114 mm diameter SDM pipes are detailed to prevent rusting caused by water and moisture, shaped with hemispherical injection molds, sealed with self-colored plastic plugs and riveted.
- Double swing frame; 2 pcs. of swing side pillar is formed by welding a 3 m Ø 114 mm (2 pieces of 2, 4 m length and 1 piece of 1 m long Ø114 mm pipe together in an H-letter shape.) and 1 piece of 3 m Ø 114 mm pipe and 2 pieces of protected polyethylene seat products are used.
- This seat is designed in a form that will wrap the user's body and is made of LLDPE (Linear Low Density Polyethylene) self-colored polyethylene plastic material weighing at least 2.5 kg.
- The swing seat railing is manufactured by LLDPE (Linear Low Density Polyethylene) blow molding manufacturing method from self-colored polyethylene plastic material weighing at least 0.5 kg.
- The swing chains are at least 6 mm thickness and coated with galvanized 25 micron hot-dip.
- The chain channels through which the chain must pass are manufactured ready to use on the product.
- The chains are connected by chain locks to the bearing wedges, which are welded together on the swing carrier.
- In order to prevent the chain locks from being easily removed, the bolt is manufactured with an allen head and galvanized coated for corrosion resistance.
- The length of the main chain is 175 cm long, and a 6 mm caliber dipped chain is used.
- Double Swing chains are manufactured in such a way as to prevent finger jamming of small children and babies.
- The distance between the bottom of the polyethylene swing seat and the ground is a maximum of 40 cm.

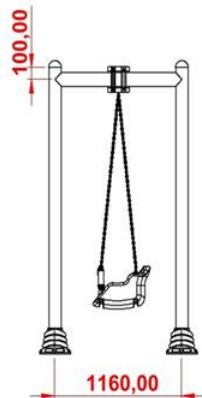
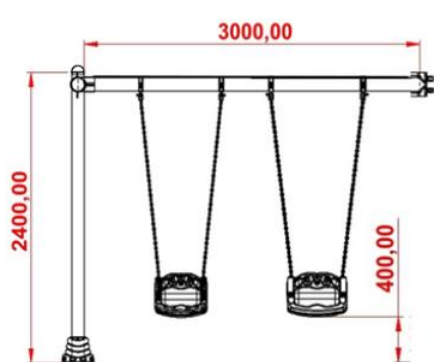

Dimensions	Side Pipe Length	230 cm
	Horizontal Pipe Length	300 cm
	Swing Seat Width	44 cm
	Swing Seat Length	32 cm
	Swing Seat Height	33 cm
	Minimum Swing Seat Weight	2,5 kg
	Minimum Weight of Swing Railing	0,5 kg
	Chain Length	175 cm
	Chain Thickness	6 mm

Ø 114 Hat Plug

- The cap plug is used to close open-ended pipes in children's playgroups, seesaws, swings, and other products.
- The cap plug is manufactured from polyethylene material for indoor and outdoor use.
- The product is resistant to UV lights.
- Its design is oval in a way that does not harm the user.
- It grasps the pipe with its 114 mm double-walled inlet and is easy to install.

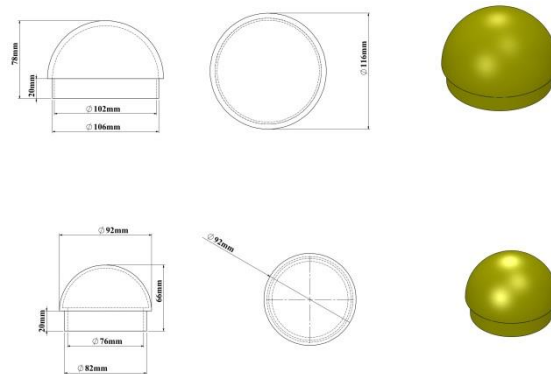

Ø 114 Anchor Cover

- Anchor caps measuring 114 mm are used to cover open-ended pipes in children's playgrounds, seesaws, swings, and other products.
- Anchor caps are produced from polythene plastic material for indoor and outdoor use.
- It is resistant to UV lights and is designed not to harm the user.
- It is manufactured as double-walled and assembled with a screwing system.

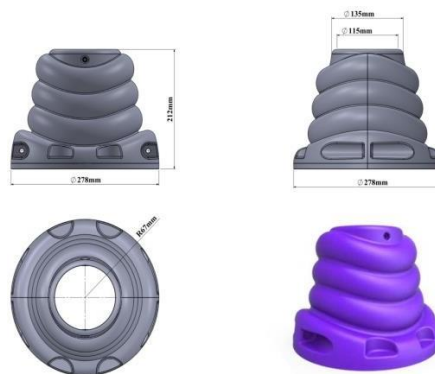

Screw Concealment

- Screw hides are used in all playgroups to prevent possible accidents and injuries.
- Screw hides; It provides an aesthetic appearance to playgroups and parking elements by allowing mounting elements such as screws and nuts to be hidden.
- Screw closures are produced from polythene plastic material by injection method, suitable for indoor and outdoor use.
- It is resistant to UV lights and is designed not to harm the user.

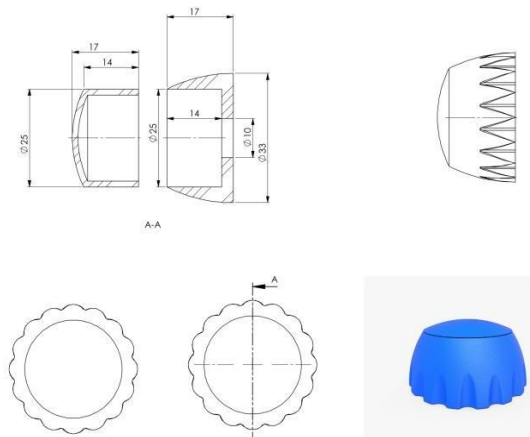

Connectors

Ø 114 Plastic Clamps

- Plastic clamps, board on the playgroup, slide entrance, railings, etc. It enables the elements to be mounted on the carrier system with a diameter of 114 mm.
- Clamps are manufactured from fibrous polyamide raw material by injection method.
- The clamp is designed in accordance with the inner diameter 114 mm pipe.
- It does not rotate on the pipe surface when tightened.
- After the clamp is connected, there are no protrusions or sharp corners that may cause injury in any part of the clamp.
- It can be produced in the desired color.

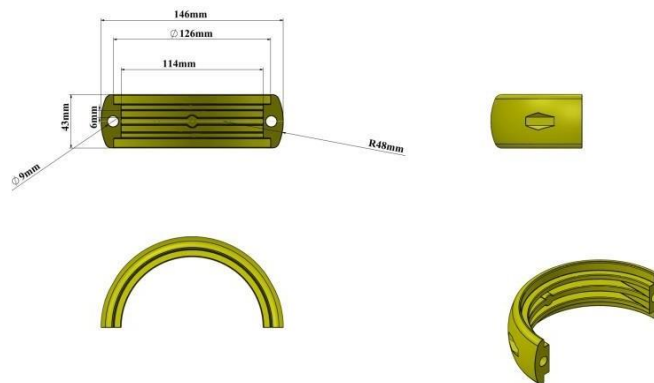

Ø114 Perpendicular Mouth

- Upright mouth, curved mouth, and platform wedge apparatus are used in the assembly of various playgrounds and sports equipment.
- It is produced from polyethylene material suitable for 114 mm pipe, suitable for indoor and outdoor use.
- The product is resistant to UV lights.
- Its design is in a structure that will not harm the user.

- It can be produced in desired colors.

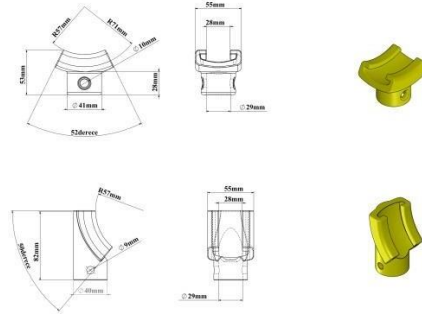

Bolts, Nuts and Washers

- The fasteners (bolts, washers, and nuts) used in-game systems are produced as GeometB321 Plus or galvanized coating to protect them against corrosion.
- There are no nut and bolt protrusions anywhere in the playset.
- Except for the camber head nut within the playgroup, all nuts are produced with fiber.

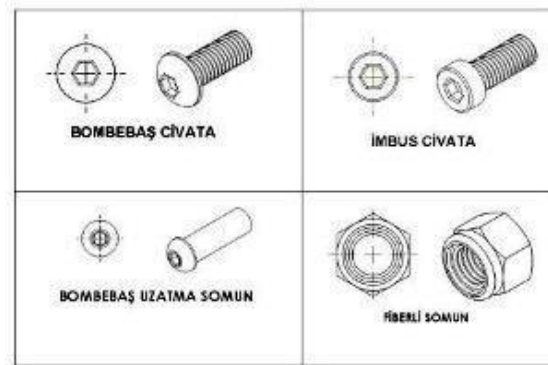

Aluminum Doetail Clamp

- Doetail clamp made of 3 mm DKP sheet is used in the swing and climbing connections.
- The inner diameter of the clamp, which consists of 2 parts, is designed in accordance with the carrier pipe with a diameter of $\text{Ø}114$ mm and is connected to the carrier H on one side and to the horizontal carrier pipe on the other.
- When it is connected to the pipe and its bolts are tightened, there is no gap and loose.

- After the clamp connection is made, there are no protrusions or sharp corners that may cause injury anywhere.
- Bolt connections are designed to not loosen on their own.
- The parts are painted with polyester-based electrostatic powder oven paint by baking.

