



PT-88



Age range
3+



Number of Users
7



Free Fall Height
2m



Height
5,44m



Assemble Area
39 m²



Sitting Area
3,60 m*7,71 m



Safety Area
6,10 m*10,21 m

PRODUCT TREE

| | | |
|----------------------------------------------------|-----------|--------------|
| IDEAL ROOF | 1 | Piece |
| TILE ROOF | 1 | Piece |
| H:100 STRAIGHT SLIDE | 1 | Piece |
| H:100 DOUBLE SLIDE | 1 | Piece |
| WOODEN FIGURED SLIDE ENTRY | 1 | Piece |
| BUGS BUNNY SLIDE ENTRY | 1 | Piece |
| FENCE PANEL | 1 | Piece |
| JUNGLE PANEL | 1 | Piece |
| H:100 CATERPILLAR STAIRS | 1 | Piece |
| H:100 FIGURED TUBE SLIDE | 1 | Piece |
| H:100 TUBE PASSING | 1 | Piece |
| 116 x 116 SQUARE PLATFORM | 2 | Piece |
| ANCHORAGE COVER | 8 | Set |
| SCREW HIDING | 12 | Piece |
| PLASTIC CLAMP WITH STRAIGHT CONNECTION PART | 20 | Piece |
| 285 CM TOWER PIPE | 8 | Piece |
| Ø27 PANEL INNER PIPE | 8 | Piece |

TECHNICAL DRAWING

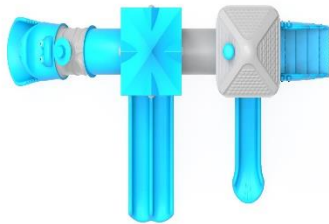
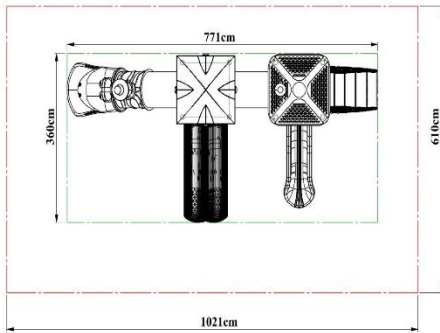
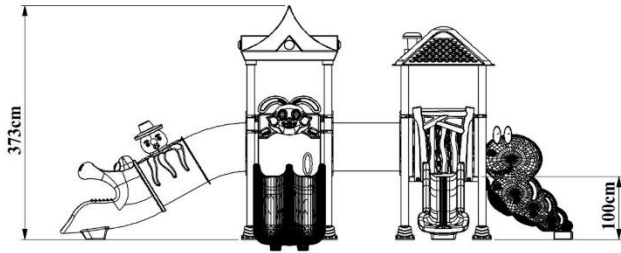

Load-bearing Construction

- Tower, slide, roof, ladder, railing, etc. The main columns that will carry the playgroup elements are manufactured from industrial pipes with a diameter of 114 mm and a wall thickness of min. 2 mm.
- The open top parts of the 114 mm diameter industrial pipes are closed and riveted with self-colored plastic pipe plugs shaped with injection molds in the form of a hemisphere with a wall thickness of 4-6 mm, detailed to prevent corrosion caused by water and moisture.

Polyethylene Products

- The raw material of polyethylene materials to be used in playgrounds is low density linear polyethylene.
- Original raw materials that do not contain any chemicals that may harm children's health and that have EN 1176-1.3 certificate are used.
- In order to prevent electrification, an anti-static agent is added to the polyethylene.
- There is no zinc in the paints used in the polyethylene raw material and the light sensitivity is between 6-8 scales.
- In polyethylene materials, the thickness is at least 5 mm in areas where there is friction and pressure.

Electrostatic Paint

- After all metal parts are manufactured, they are immersed in an iron phosphate bath with 1% concentration at 50 degrees for 15 minutes after rinsing in the dust and degreasing bath with 5% concentration at 70 degrees for 10 minutes.
- Afterward, it is rinsed with clean water again and drying processes are carried out.
- Before the static paint process, sanding is applied in a way to prevent rusting, which may be caused by dust and particles that can settle on the metal parts as a result of air circulation during the drying phase during the resting period.
- After this stage, the material is covered with polyester-based powder paint with a thickness of 60-80 microns, which prevents heating (color fading) in the sun, and then it is heated in an oven at a temperature of at least 200-220 degrees for 10 minutes, and the painting process is completed.

Pipes

- Tower pipes; It is manufactured from SDM pipe with a height of 285 cm a diameter of 114 mm, and a wall thickness of min. 2 mm.
- The tower pipes are produced in one piece and perfectly, from horizontal and vertical pipes in length cut according to the determined heights, with a minimum of 2250 mm.
- Pipes with seam marks on the surface are not used in production.
- Adding the length of the pipes, welding, etc. is not extended by the procedure.
- In order to prevent water, moisture, and foreign matter from entering the upper parts of these pipes, colored plastic pipe plugs produced by the injection method are fixed and closed to the pipes with a riveting system.
- The connection points of the pipes with the concrete floor are joined by the sheet metal flange welding method with the size of 20*20*6 mm.
- Connection of the Tower Pipes with the platform the half-moon-shaped ears welded according to the platform size, produced from 6 mm wall thickness, are welded to the pipes and these ears are connected to the platform with the screwing system by means of galvanized bolts and nuts.
- A polyester-based electrostatic powder paint coating process is performed and it is baked in a 200°C oven for 20 minutes.
- Tower pipes are closed with anchor caps produced by injection after assembly.
- 100 cm high, Ø27 elektrostatic paint panel inner pipe is used.



| | | |
|-------------------|----------------|-----------|
| Dimensions | Diameter | Ø 114 mm |
| | Wall Thickness | Min. 2 mm |

116x116 Square Platform

- The platform is manufactured from perforated sheet metal with a minimum size of 116 cm x 116 cm x 8 cm and a minimum wall thickness of 1.5 mm-2 mm.
- Straight designed surface; It is designed to prevent slipping and not allow water retention.
- In the middle of the platform, support sheets are welded to the lower part in order to prevent the sheet from flexing.
- The corners of the platform are manufactured in the form of a quarter circle, enclosing the 114 mm pipe.
- Before the coating process, the sheets are washed with special chemicals, cleared of oil and dirt that will prevent the coating on them, and then coated with the priming method.
- After the priming process, the upper surface of the platform is hot-dip method with an anti-static material mixture with a hardness of -60 ± 5 share A, a density of 1 gr/cm³, minimum kgf/cm² breaking strength, 650-700% breaking elongation, and 100 m³ (max) abrasion. PVC (Plastisol) coating is made.
- PVC thickness is produced at a minimum of 2 mm at each point.
- The platform is attached to the square platform by screwing and its assembly is provided.

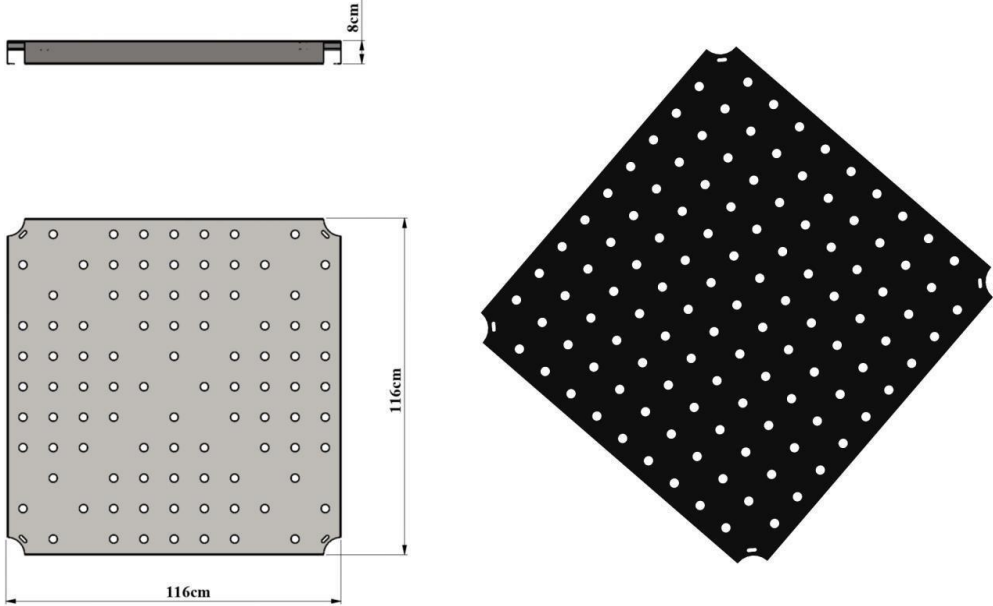

| | | |
|-------------------|---------------------------|-------------|
| Dimensions | Platform Dimensions | 116*116 |
| | Sheet Thickness | 2 mm - 8 cm |
| Features | Plastisol Coated Platform | |

H:100 Plastic Stair

- The stair is manufactured from self-colored polyethylene plastic material, LLDPE (Linear Low Density Polyethylene) rotation molding method, with a minimum of 4 steps, in a way that can reach 100 cm level difference from the ground to the platform.
- There are patterns designed for children on the stair railing.
- Stair railing is manufactured from self-colored polyethylene plastic material LLDPE (Linear Low Density Polyethylene) by rotation molding method.
- In order for the product surface to be smooth; Sandblasting is applied to the surface of the mold made of aluminum or equivalent material and it is produced by passing the Teflon coating process for surface brightness.

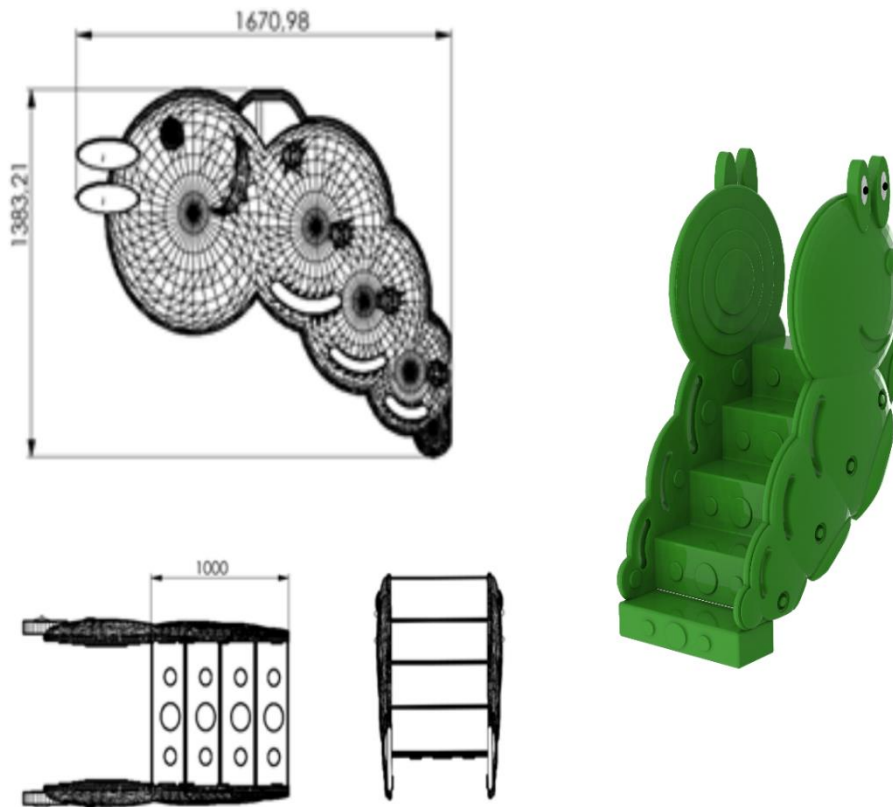

| | | |
|-------------------|-----------------|--------|
| Dimensions | Platform Height | 100 cm |
| | Railing Height | 167 cm |
| | Railing Width | 138 cm |
| Features | Min. Weight | 50 kg |
| | Raw materials | LLDPE |

Wooden Figured Straight Slide Entry

- It is manufactured from self-colored polyethylene plastic material as a one-piece and double-walled by rotation molding method with low density (LLDPE Linear Low-Density Polyethylene) designed to prevent falling into the slide entrances.
- Plastic clamps and vertical mouth connection apparatuses are attached to the Ø 27 mm. inner pipe ends attached to the slides, and the Ø 114 mm tower is fixed to the pipes and screwed from the parts of the panels that sit on the platform.
- In order for the product surface to be smooth; It is produced by sandblasting the surface of the mold made of aluminum or its equivalent material and undergoing a Teflon coating process for surface brightness.

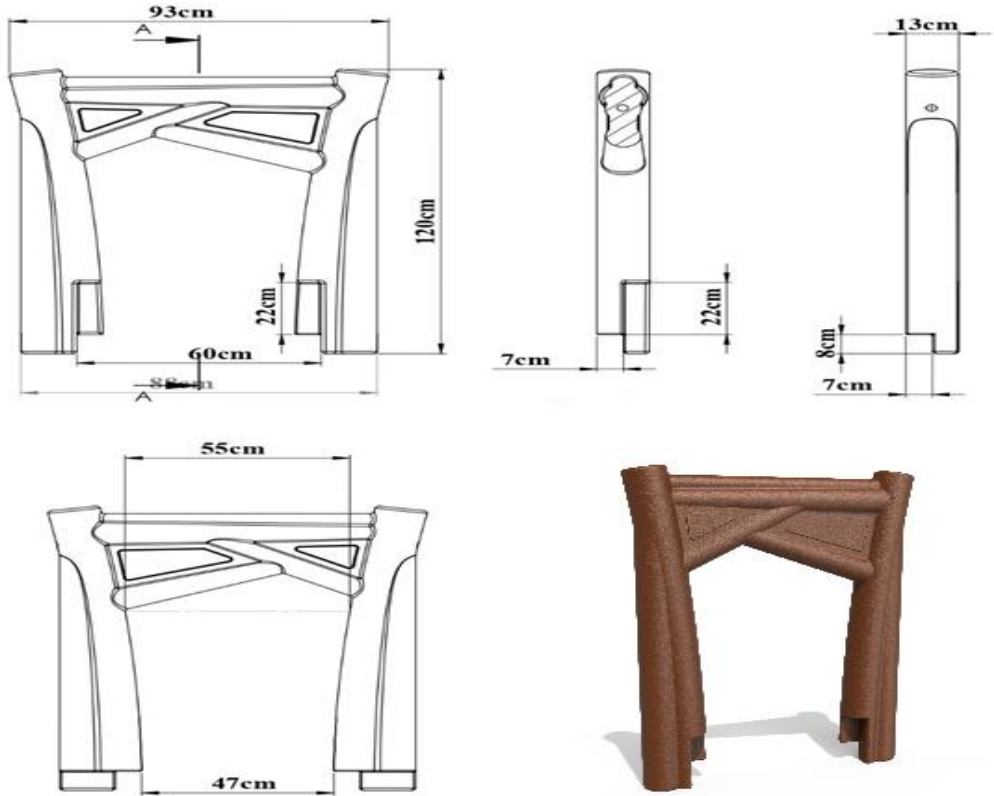

| | | |
|-------------------|--------------|--------|
| Dimensions | Length | 120 cm |
| | Width | 93cm |
| | Input Width | 55 cm |
| Features | Min. Weight | 8,5 kg |
| | Raw material | LLDPE |

Bugs Bunny Slide Entry

- Bugs Bunny Slide Entry are manufactured from self-colored polyethylene LLDPE (Linear Low-Density Polyethylene) material as double-walled by rotation molding method.
- Bugs Bunny Slide Entry are fixed to the main construction with the help of a polyamide-based clamp system with galvanized pipes of 67*93 cm dimensions, Ø 27 mm diameter from the top, and 2 mm wall thickness.
- The dyestuffs used in coloring are suitable for child health.

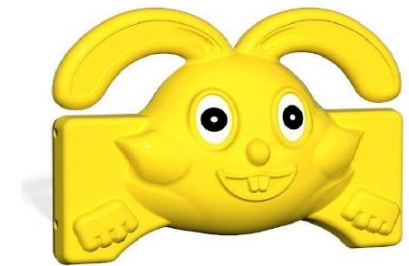
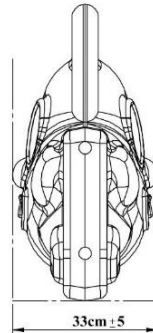
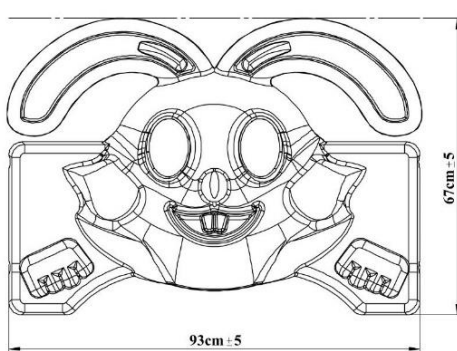

| | | |
|-------------------|-----------------|--------|
| Dimensions | Height | 67 cm |
| | Width | 93 cm |
| | Panel thickness | 33 cm |
| Features | Min. Weight | 4,5 kg |
| | Raw material | LLDPE |

Fence Panel

- Fence panel are manufactured from self-colored polyethylene LLDPE (Linear Low-Density Polyethylene) material as double-walled by rotation molding method.
- The fence panels are fixed to the main construction with the help of a polyamide-based clamp system with pipes of 90x110 cm dimensions, Ø 27 mm diameter from the top The dyestuffs used in coloring are suitable for child health.

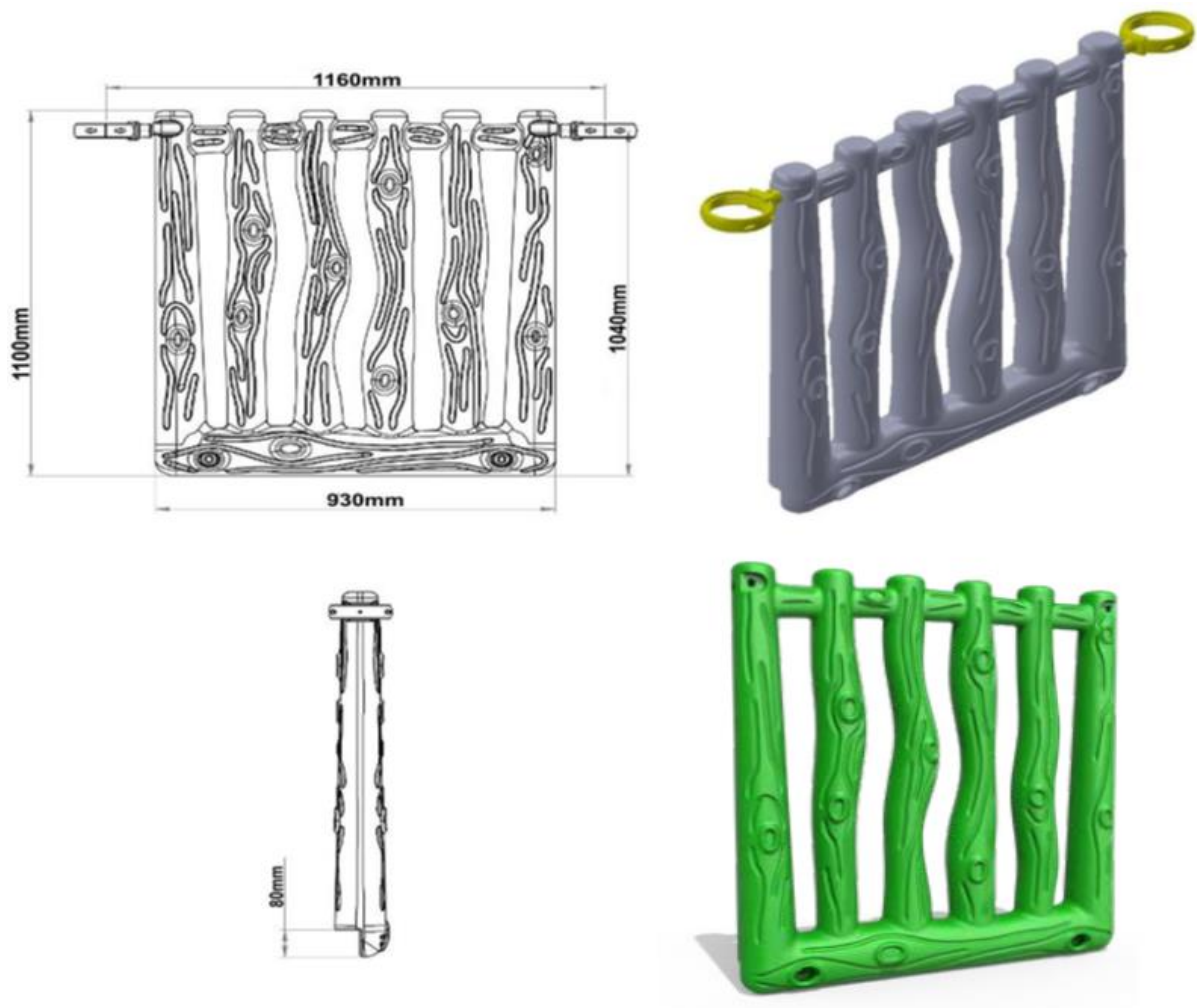

| | | |
|-------------------|-----------------|--------|
| Dimensions | Height | 110 cm |
| | Width | 90 cm |
| | Panel thickness | 7 cm |
| Features | Min. Weight | 8 kg |
| | Raw material | LLDPE |

Jungle Panel

- Jungle panel are manufactured from self-colored polyethylene LLDPE (Linear Low-Density Polyethylene) material as double-walled by rotation molding method.
- The Jungle panel are fixed to the main construction with the help of a polyamide-based clamp system with pipes of 93x170 cm dimensions, Ø 27 mm diameter from the top.
- The dyestuffs used in coloring are suitable for child health.

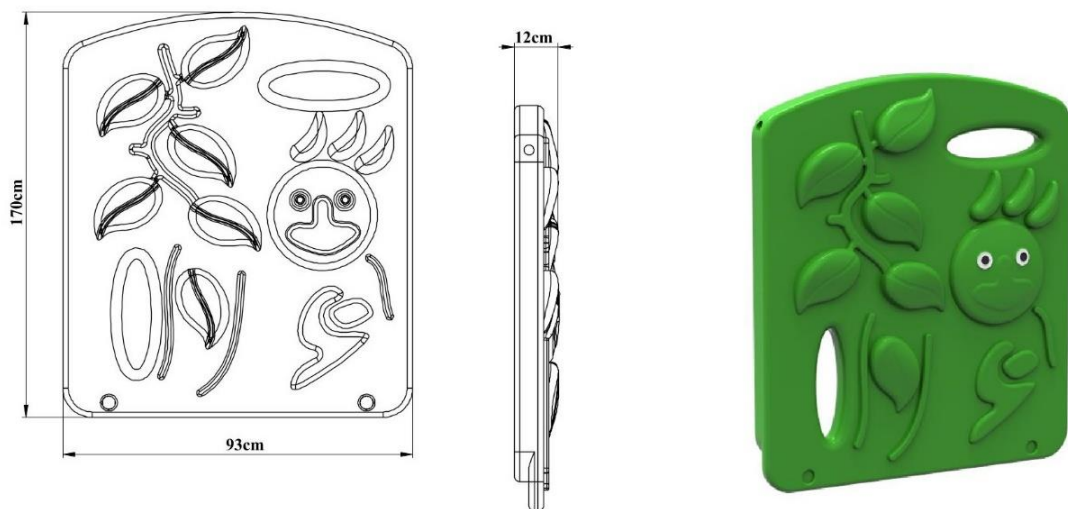

| | | |
|-------------------|--------------|--------|
| Dimensions | Height | 170 cm |
| | Width | 93 cm |
| Features | Min. Weight | 12 kg |
| | Raw material | LLDPE |

H:100 Straight Slide

- LLDPE (Linear Low-Density Polyethylene) made of self-colored polyethylene plastic material, which is designed to slide from a 100 cm high platform, has a minimum length of 2 meters, is produced in a single piece and double-walled form with a minimum weight of 22 kg.
- It is manufactured in such a way that the inner height dimension of the side protective corners of the slide is 17 cm, the width of the sliding surface is 40 cm, and the slope is 25-30 degrees.
- The slide is fixed to the ground with a metal apparatus from the anchorage point at the bottom of the slide's exit point.
- In order for the product surface to be smooth; Sandblasting is applied to the surface of the mold made of aluminum or its equivalent material, and it is produced by passing the Teflon coating process for surface brightness.
- A flat slide entrance panel is used to ensure safety at the slide entrance.
- LLDPE (Linear Low-Density Polyethylene) from self-colored polyethylene plastic material is produced in one piece by rotation molding method.
- Plastic clamps and vertical mouth connection apparatuses are attached to the $\text{\O} 27 \text{ mm}$ inner pipe ends attached to the inside of the polyethylene flat slide entrance panels and fixed to the $\text{\O} 114 \text{ mm}$ tower pipes.

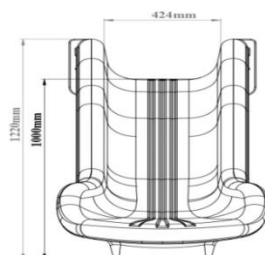
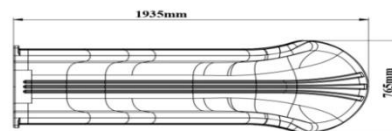

| | | |
|-------------------|-------------------|--------|
| Dimensions | Platform Height | 100 cm |
| | Side Wall Length | 17 cm |
| | Slide Inner Width | 40 cm |
| | Slide Length | 210 cm |
| Features | Raw material | LLDPE |
| | Min. Slide Weight | 22 kg |

H:100 Double Slide

- LLDPE (Linear Low-Density Polyethylene) made of self-colored polyethylene plastic material, which is designed to slide from a 100 cm high platform is produced in a single piece and double-walled form with a minimum weight of 40 kg.
- It is manufactured in such a way that the inner height dimension of the side protective corners of the slide is 25 cm, the width of the sliding surface is 42 cm, and the slope is 25-30 degrees.
- A flat slide entrance panel is used to ensure safety at the slide entrance.
- In order for the product surface to be smooth; Sandblasting is applied to the surface of the mold made of aluminum or its equivalent material, and it is produced by passing the Teflon coating process for surface brightness.
- The slide is fixed to the ground with a metal apparatus from the anchorage point at the bottom of the slide's exit point.

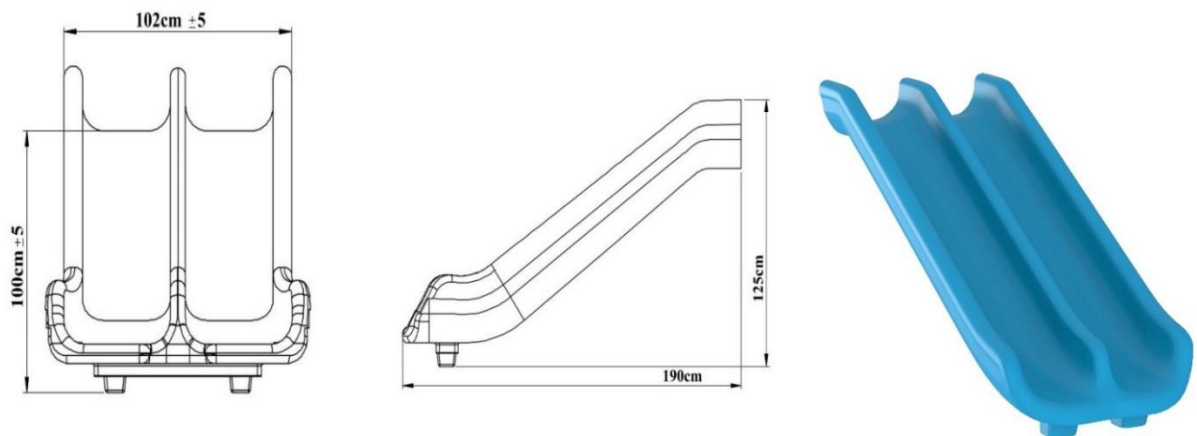

| | | |
|-------------------|-------------------|--------|
| Dimensions | Platform Height | 100 cm |
| | Side Wall Length | 25cm |
| | Slide Inner Width | 42 cm |
| | Slide Length | 190 cm |
| Features | Raw material | LLDPE |
| | Min. Slide Weight | 40 kg |

H:100 Figured Tube Slide

- H:100 figured tube slide with a minimum length of 3,46 m, designed to slide from a platform with a height of 100 cm; tube inlet, 1 pcs 35 degree tube elbow, 1 pcs 80 cm figured tube and figured tube outlet are manufactured from a total of 4 parts and from self-colored polyethylene plastic material LLDPE (Linear Low Density Polyethylene) rotation molding method.
- The product produced as disassembled; It is made a whole by assembling the given tube parts to each other according to the given angles.
- The slide is fixed to the ground with a metal apparatus from the anchorage point at the bottom of the slide's exit point.
- In order for the product surface to be smooth; Sandblasting is applied to the surface of the mold made of aluminum or its equivalent material, and it is produced by passing the Teflon coating process for surface brightness.

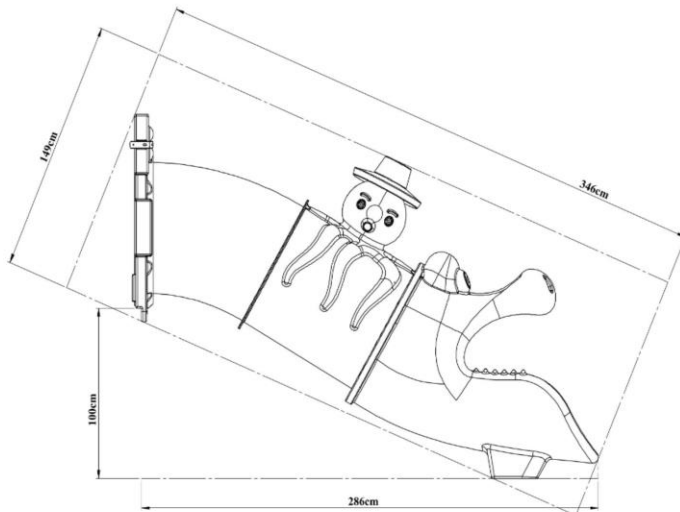

| | | |
|-------------------|----------------------|--------|
| Dimensions | Platform Height | 100 cm |
| | Tube Length | 346 cm |
| | Panel Entry Diameter | 75 cm |
| Features | Raw materials | LLDPE |
| | min. Slide Weight | 74 kg |

Tube Slide Entry

- It is manufactured from self-colored polyethylene plastic material as a one-piece and double-walled by rotation molding method with low density (LLDPE Linear Low-Density Polyethylene) designed to prevent falling into the slide entrances.
- Plastic clamps and vertical mouth connection apparatuses are attached to the Ø 27 mm inner pipe ends attached to the slides, and the Ø 114 mm tower is fixed to the pipes and screwed from the parts of the panels that sit on the platform.
- In order for the product surface to be smooth; It is produced by sandblasting the surface of the mold made of aluminum or its equivalent material and undergoing a Teflon coating process for surface brightness.

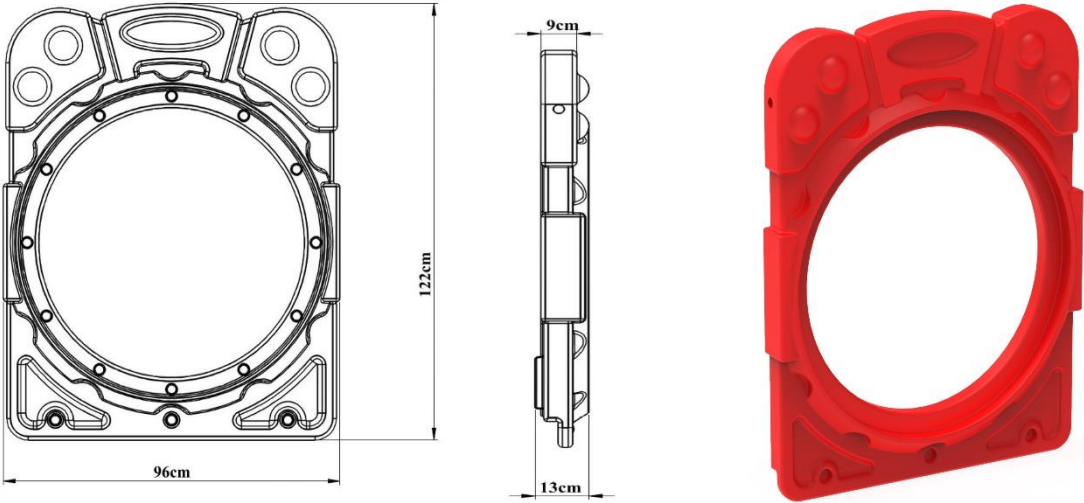

| | | |
|-------------------|--------------|--------|
| Dimensions | Length | 122 cm |
| | Width | 96 cm |
| | Input Width | 75 cm |
| Features | Min. Weight | 9 kg |
| | Raw material | LLDPE |

Figured 80 Cm Tube

- 80 cm figured tubes forming tube slides are manufactured as a single piece from self-colored polyethylene plastic material, LLDPE (Linear Low Density Polyethylene) rotation molding method.
- Installation of the product is provided by screwing method.
- In order for the product surface to be smooth; Sandblasting is applied to the surface of the mold made of aluminum or its equivalent material, and it is produced by passing the Teflon coating process for surface brightness.

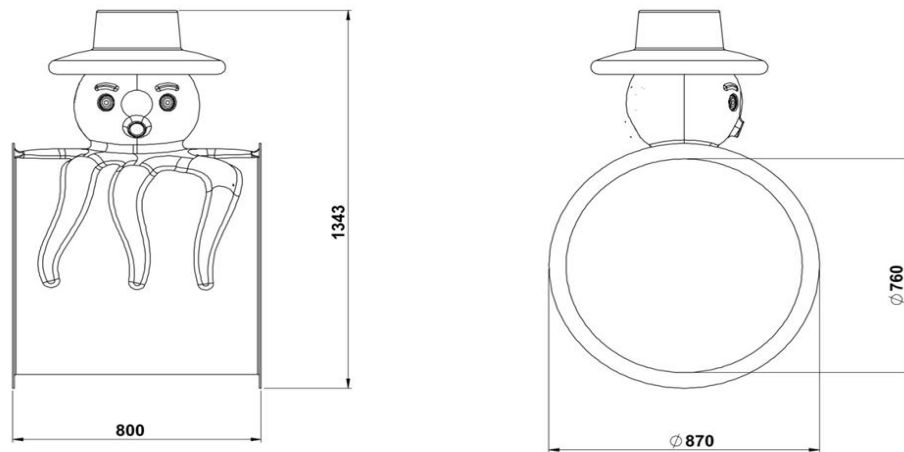

| | | |
|-------------------|----------------|-------|
| Dimensions | Tube Length | 80 cm |
| | Tube Diameter | 87 cm |
| Features | Minimum Weight | 19 kg |
| | Raw materials | LLDPE |

35° Tube

- The 35° tubes that make up the tube slides are manufactured from self-colored polyethylene plastic material, LLDPE (Linear Low Density Polyethylene) by rotation molding method as a single piece, providing an inclination of 35 degrees.
- Installation of the product is provided by screwing method.
- In order for the product surface to be smooth; Sandblasting is applied to the surface of the mold made of aluminum or its equivalent material, and it is produced by passing the Teflon coating process for surface brightness.

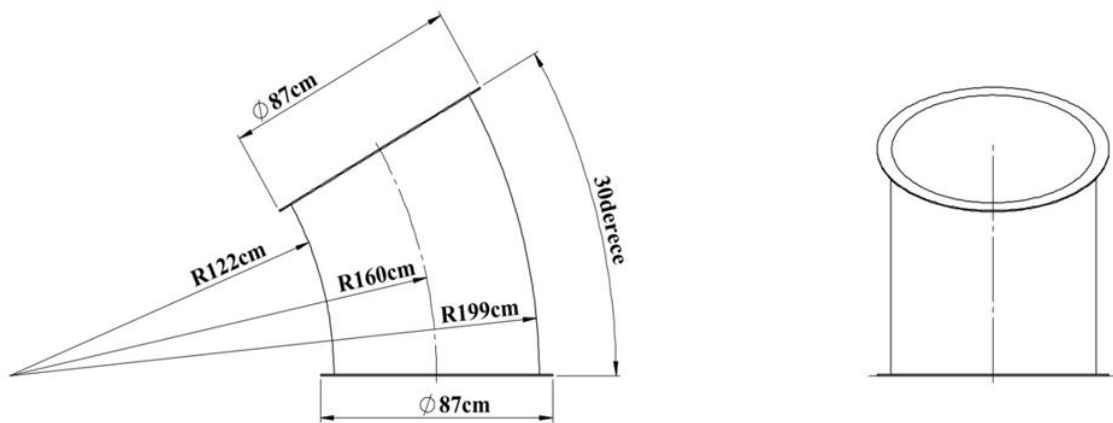

| | | |
|-------------------|----------------|-------|
| Dimensions | Tube Angle | 35° |
| | Tube Diameter | 87 cm |
| Features | Minimum Weight | 17 kg |
| | Raw materials | LLDPE |

Tube Output

- The tube outlet forming the tube slides is manufactured as a single piece by rotation molding method from self-colored polyethylene plastic material, LLDPE (Linear Low Density Polyethylene) so that the child can come out of the play element safely.
- Installation of the product is provided by screwing method.
- In order for the product surface to be smooth; Sandblasting is applied to the surface of the mold made of aluminum or its equivalent material, and it is produced by passing the Teflon coating process for surface brightness.

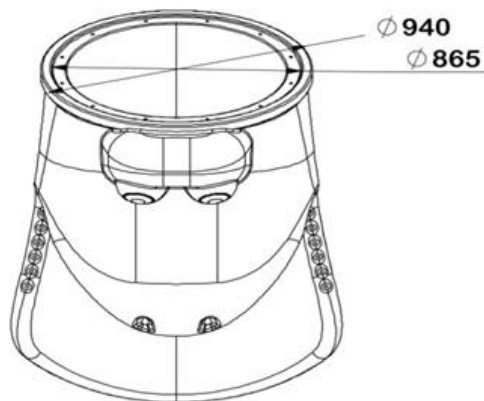
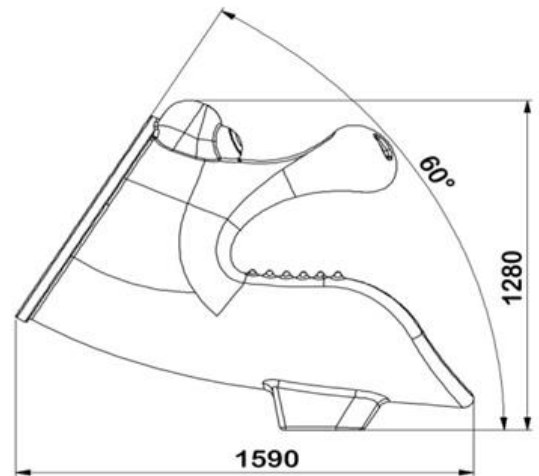
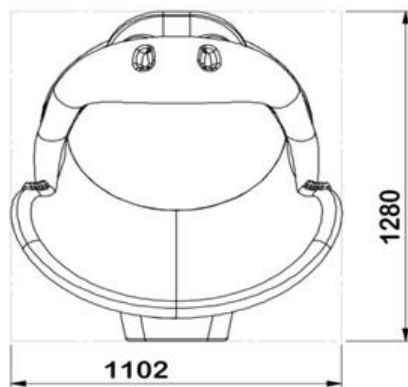

| | | |
|-------------------|----------------------|--------|
| Dimensions | Tube Output Length | 160 cm |
| | Tube Outlet Diameter | 86 cm |
| Features | Minimum Weight | 25 kg |
| | Raw materials | LLDPE |

100 Cm Tube Passage

- H:100 tube passage with a minimum length of 1 m, designed to allow passage between two platforms; It is manufactured from 3 parts, 2 pcs tube inlets and 1 pcs 110 degree tube, and from self-colored polyethylene plastic material, LLDPE (Linear Low Density Polyethylene) rotation molding method.
- Plastic clamps and vertical mouth connection apparatuses are attached to the ends of $\text{Ø} 27$ inner pipes attached to the tube passages, and 114 towers are fixed to the pipes and screwed from the parts of the panels that sit on the platform.
- The product produced as disassembled; It is made a whole by assembling the given tube parts to each other according to the given angles.
- In order for the product surface to be smooth; Sandblasting is applied to the surface of the mold made of aluminum or its equivalent material, and it is produced by passing the Teflon coating process for surface brightness.

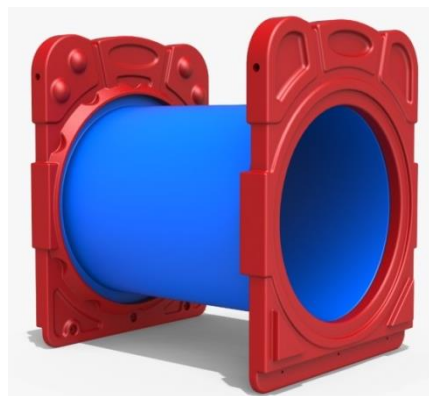
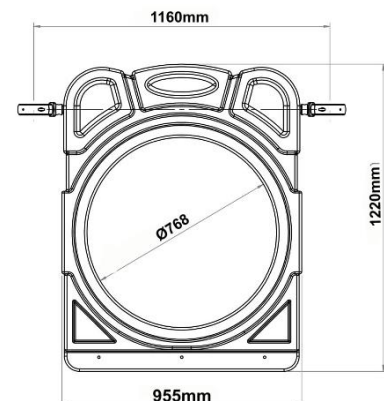
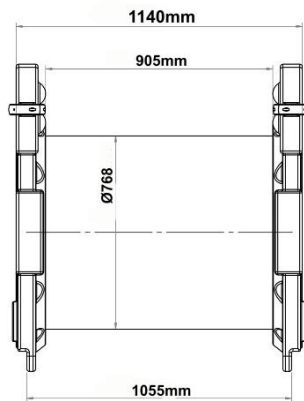

| | | |
|-------------------|----------------------|--------|
| Dimensions | Tube Passage Length | 124 cm |
| | Panel Entry Diameter | 75 cm |
| Features | Min. Weight | 42 kg |
| | Raw material | LLDPE |

Ideal Roof

- The ideal roof is manufactured from polyethylene plastic material, LLDPE (Linear Low-Density Polyethylene) with a minimum height of 88,5 cm, by rotation molding method, in two parts as body and upper apparatus, in self-color.
- In accordance with TS EN 1176-1, when measuring on the platform, the height between the platform and the roof is at least 1800 mm.
- The ideal roof is manufactured to be directly connected to the main construction.
- No connecting element is used in between.
- The apparatus in its four corners are mounted with screws.

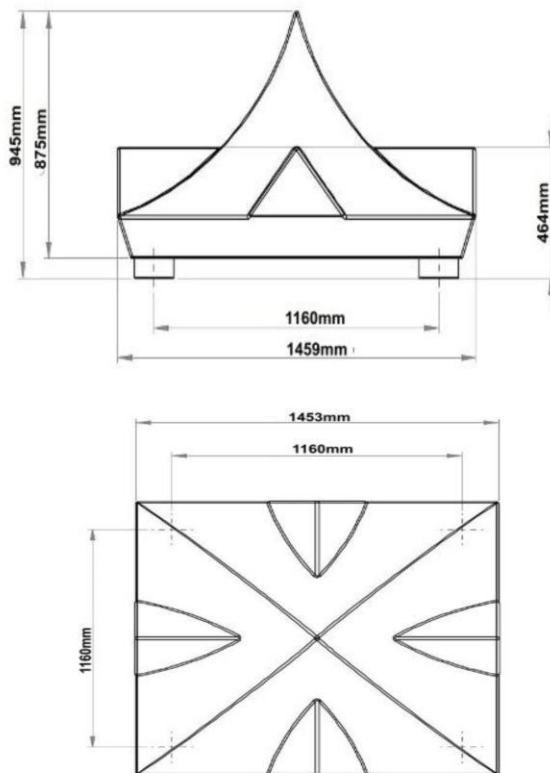

| | | |
|-------------------|------------------------|---------|
| Dimensions | Depth | 148 cm |
| | Width | 148 cm |
| | Min. Ideal Roof Height | 88,5 cm |
| Features | Min. Ideal Roof Weight | 23 kg |
| | Raw material | LLDPE |

Tile Roof

- The tile roof is manufactured from polyethylene plastic material (LLDPE Linear Low Density Polyethylene) with a minimum height of 62 cm by rotation molding method in 2 parts, self-colored.
- In accordance with TS EN 1176-1, when measuring on the platform, the height between the platform and the roof is at least 1800 mm.
- The tile roof must be directly connected to the main construction.
- No connecting element is used in between.

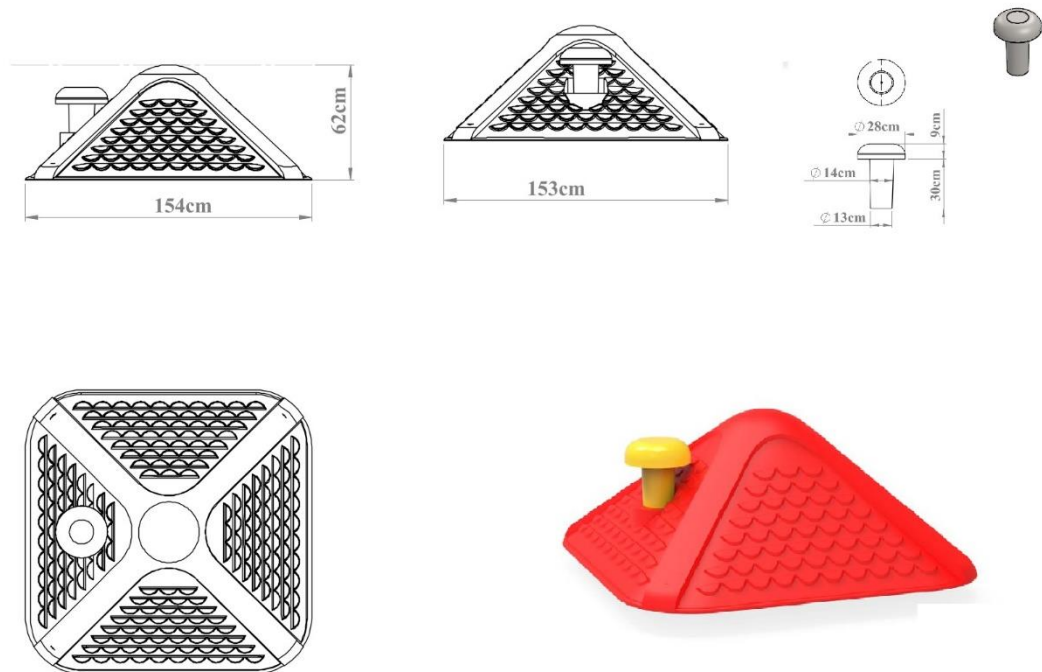

| | | |
|-------------------|-----------------------|--------|
| Dimensions | Width | 154 cm |
| | Length | 153 cm |
| | min. Tile Roof Height | 62 cm |
| Features | min. Tile Roof Weight | 23 kg |
| | Raw materials | LLDPE |

Ø 114 Hat Plug

- The cap plug is used to close open-ended pipes in children's playgroups, seesaws, swings, and other products.
- The cap plug is manufactured from polyethylene material for indoor and outdoor use.
- The product is resistant to UV lights.
- Its design is oval in a way that does not harm the user.
- It grasps the pipe with its 114 mm double-walled inlet and is easy to install.

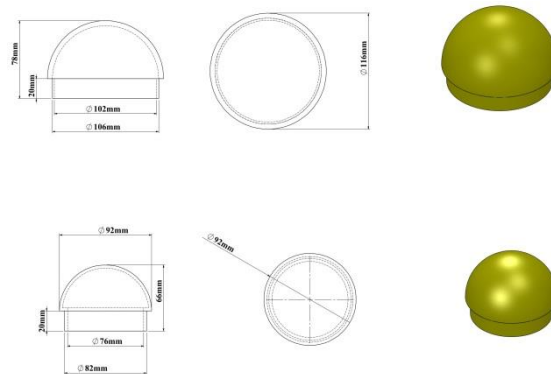

Ø 114 Anchor Cover

- Anchor caps measuring 114 mm are used to cover open-ended pipes in children's playgrounds, seesaws, swings, and other products.
- Anchor caps are produced from polythene plastic material for indoor and outdoor use.
- It is resistant to UV lights and is designed not to harm the user.
- It is manufactured as double-walled and assembled with a screwing system.

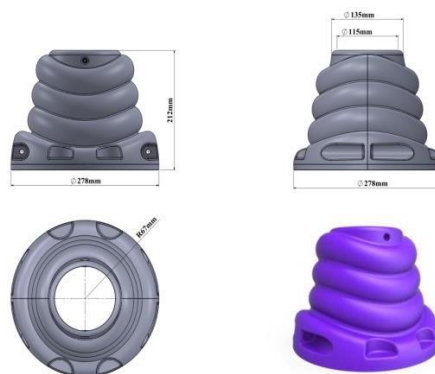

Screw Concealment

- Screw hides are used in all playgroups to prevent possible accidents and injuries.
- Screw hides; It provides an aesthetic appearance to playgroups and parking elements by allowing mounting elements such as screws and nuts to be hidden.
- Screw closures are produced from polythene plastic material by injection method, suitable for indoor and outdoor use.
- It is resistant to UV lights and is designed not to harm the user.

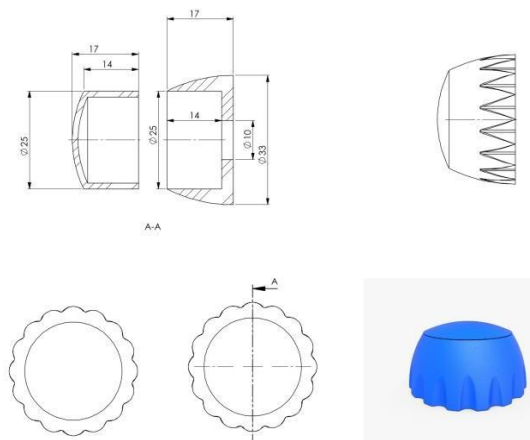

Connectors

Ø 114 Plastic Clamps

- Plastic clamps, board on the playgroup, slide entrance, railings, etc. It enables the elements to be mounted on the carrier system with a diameter of 114 mm.
- Clamps are manufactured from fibrous polyamide raw material by injection method.
- The clamp is designed in accordance with the inner diameter 114 mm pipe.
- It does not rotate on the pipe surface when tightened.
- After the clamp is connected, there are no protrusions or sharp corners that may cause injury in any part of the clamp.
- It can be produced in the desired color.

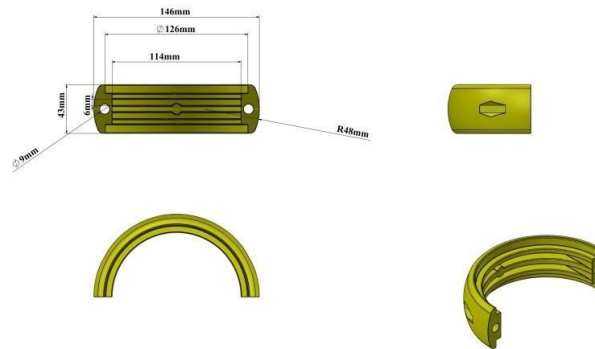

Ø114 Perpendicular Mouth

- Upright mouth, curved mouth, and platform wedge apparatus are used in the assembly of various playgrounds and sports equipment.
- It is produced from polyethylene material suitable for 114 mm pipe, suitable for indoor and outdoor use.
- The product is resistant to UV lights.
- Its design is in a structure that will not harm the user.

- It can be produced in desired colors.

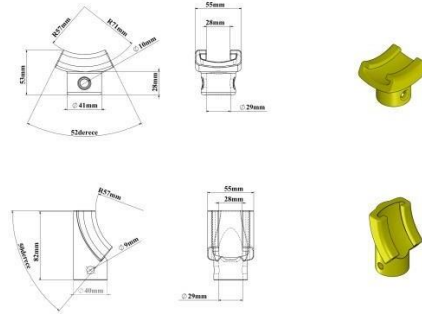

Bolts, Nuts and Washers

- The fasteners (bolts, washers, and nuts) used in-game systems are produced as GeometB321 Plus or galvanized coating to protect them against corrosion.
- There are no nut and bolt protrusions anywhere in the playset.
- Except for the camber head nut within the playgroup, all nuts are produced with fiber.

