

## **PY-124 150cm Straight Bridge And Bugs Bunny Fence Rails**

- The platform is manufactured from perforated sheet metal with a minimum size of 150 cm x 103 cm x 8 cm and a minimum wall thickness of 1.5 mm-2 mm.
- Flat designed surface; It is designed to prevent slipping and not allow water retention.
- In the middle of the platform, support sheets are welded to the lower part in order to prevent the sheet from flexing.
- The corners of the platform are manufactured in the form of a quarter circle, enclosing the 114 mm pipe.
- Before the coating process, the sheets are washed with special chemicals, cleared of oil and dirt that will prevent the coating on them, and then coated with the priming method.
- After the priming process, the upper surface of the platform is hot-dip method with an anti-static material mixture with a hardness of  $-60 \pm 5$  share A, a density of 1 gr/cm<sup>3</sup>, minimum kgf/cm<sup>2</sup> breaking strength, 650-700% breaking elongation, and 100 m<sup>3</sup> (max) abrasion. PVC (Plastisol) coating is made.
- PVC thickness is produced at a minimum of 2 mm at each point.
- Bugs Bunny Fence are manufactured from self-colored polyethylene LLDPE (Linear Low-Density Polyethylene) material as double-walled by rotation molding method.
- The fence are fixed to the main construction with the help of a polyamide-based clamp system pipes of 118x150 cm dimensions, 27 mm diameter from the top..
- The dyestuffs used in coloring are suitable for child health.

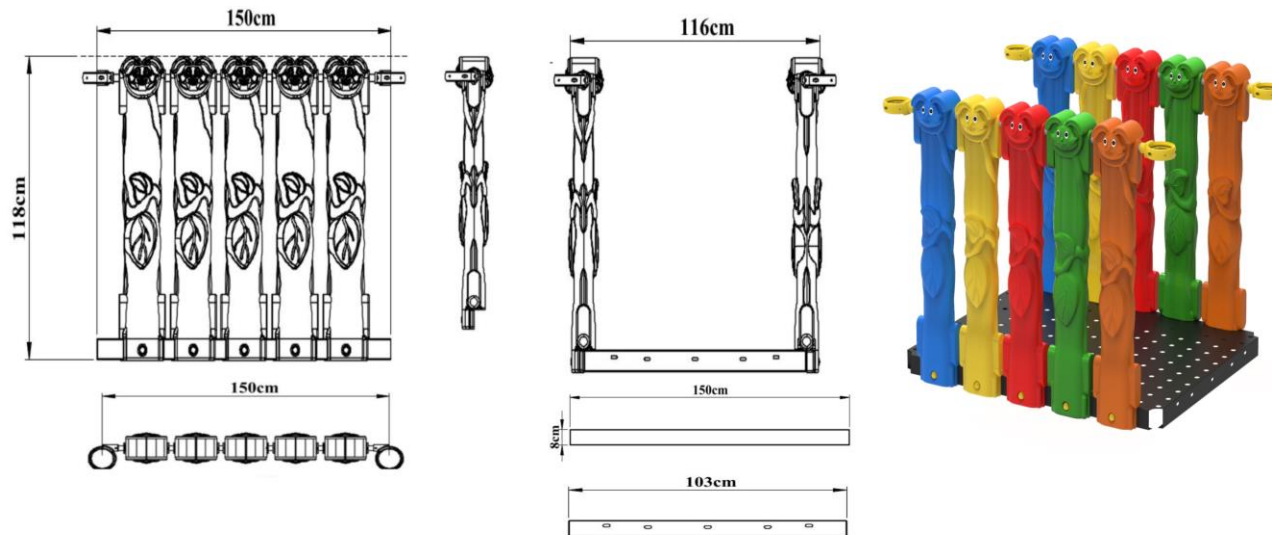

<b>Dimensions</b>	Platform Dimensions	103cm*150 cm
	Sheet Thickness	2 mm - 8 cm
	Fence Dimensions	118cm*150cm
<b>Features</b>	Plastisol Coated Platform	