

## PY-76

## Swing Rail

- Swing seat railing is manufactured from self-colored polyethylene plastic material LLDPE (Linear Low Density Polyethylene) with a weight of at least 0.5 kg, by blow molding manufacturing method.
- The chain channels through which the chain must pass are manufactured ready to use on the product.

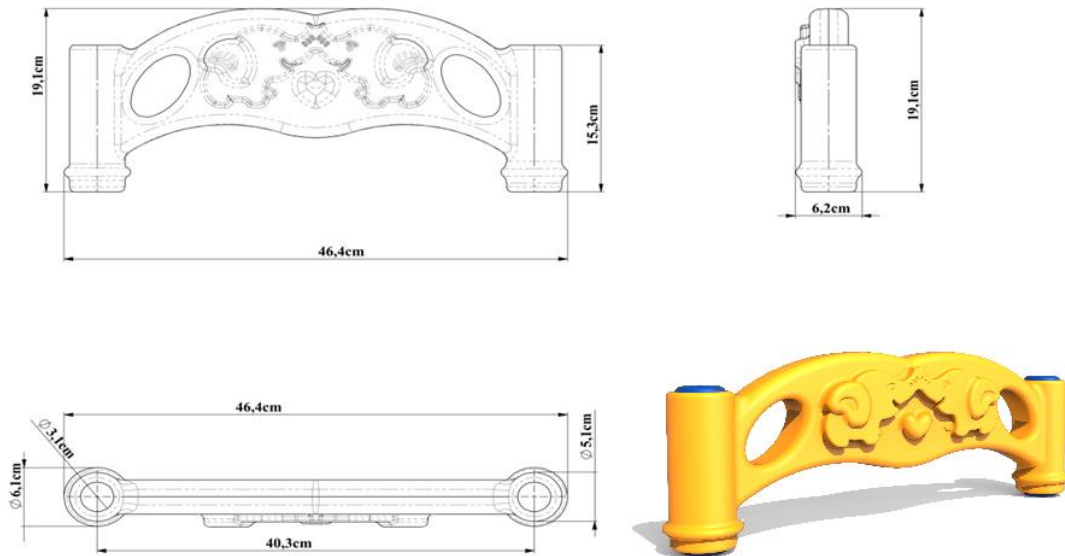

<b>Dimensions</b>	Railing Width	47 cm
	Railing Length	19 cm
	Railing Weight	0,5 kg