

PY-98

Ø 114 Seesaw Seat

- The seesaw seat is manufactured using LLDPE (Linear Low Density Polyethylene) rotation molding method from a self-colored polyethylene plastic material weighing at least 1,5 kg.
- The seesaw seat is designed to prevent the user from slipping back.
- There are handles on the seat where the user can get support.
- The handles are not mounted afterwards.
- At the lower point of the seesaw seat, pipes that can absorb the impact are welded in order to provide a soft collision with the ground during use.

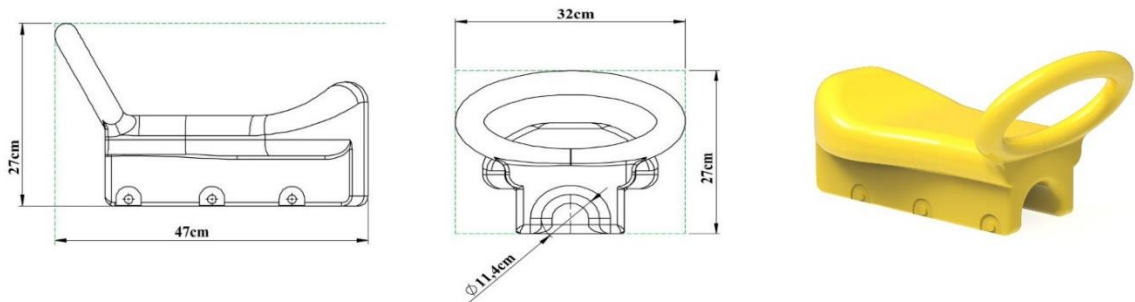

Dimensions	Seesaw Seat Width	47,5 cm
	Seesaw Seat Length	27 cm
Features	Minimum Seesaw Seat Weight	1,5 kg
	Raw materials	LLDPE